

Fireline™ 520 Series

Fire Barrier Systems - Fire Blanket
Floors, Walls, Ceilings and Roofs

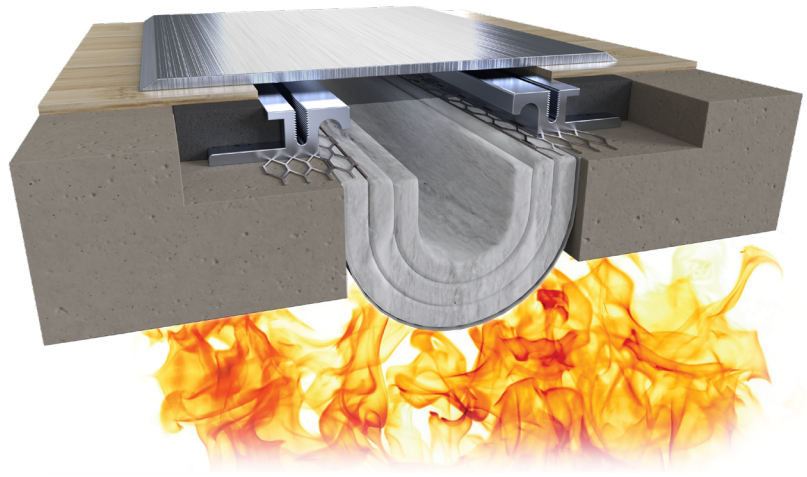

Movement Rating \pm 50%

Product Guide



Thermal



Exterior



Interior



Fire Rated
Option



Vapor Barrier
Option

- ▶ 1, 2 and 3 hour rated floor and wall systems.
- ▶ Tested in accordance with:
 - UL 2079/ ULC S-115 "FTH"
 - (FTH: Rating Fire, Temperature and Hose)
 - ASTM-E119/E1399/E1966
 - BS EN 1366.4
- ▶ 80% movement capability available.
- ▶ \pm 50% (100%) lateral shear capable.
- ▶ Applicable for the following joint widths:
 - 2hr, TM/IM - 4" [102mm] to 24" [610mm]
 - 3hr, TM/IM - 6" [152mm] to 24" [610mm]
 - 2hr/3hr, BM - 6" [152mm] to 24" [610mm]
- ▶ Sections come with pre-attached flanges and factory made male to female splices, eliminating the need for complex field manipulation at seams.
- ▶ Pre-attached flanges dramatically reduce installation costs and ensure uniform installation.
- ▶ No labor intensive fire caulk required for installation.
- ▶ Multiple mounting configurations available for both wall and floor conditions:
 - TM - top (surface) mount
 - IM - inside (recessed) mount
 - BM - bottom Mount
- ▶ "Water Guard" systems are available to protect the blanket system and fire rating during and after construction of open structures such as parking facilities and stadiums (reference alternate technical data sheet).

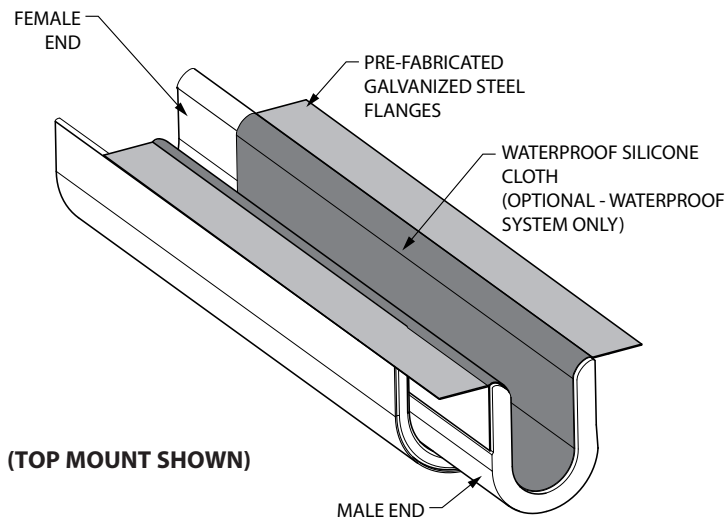

IPC.1831/Rev.12

Fireline™ 520 Series

Fire Barrier Systems

***NOTE:** Rated substrate hourly rating must not exceed the hourly rating of the F520 blanket assembly. Construction of the rated substrate is by others.

Top Mount - Ceiling to Ceiling (300-A07-075 System Shown)

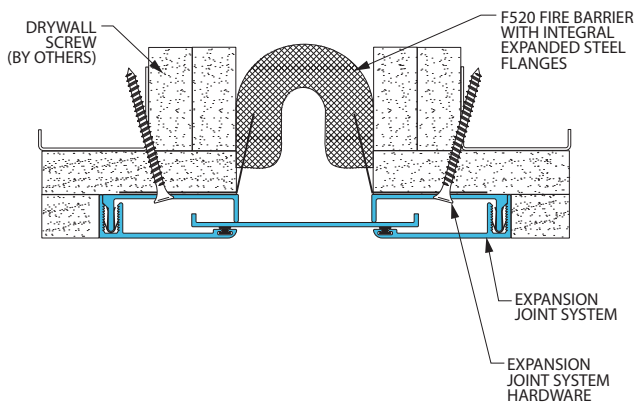

Inside Mount - Wall to Wall (811-A07-075 System Shown)

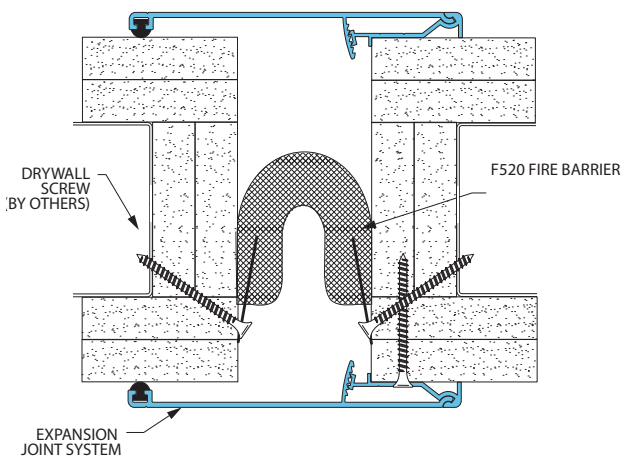

Top (Flush) Mount - Floor to Floor (300-A01-100 System Shown)

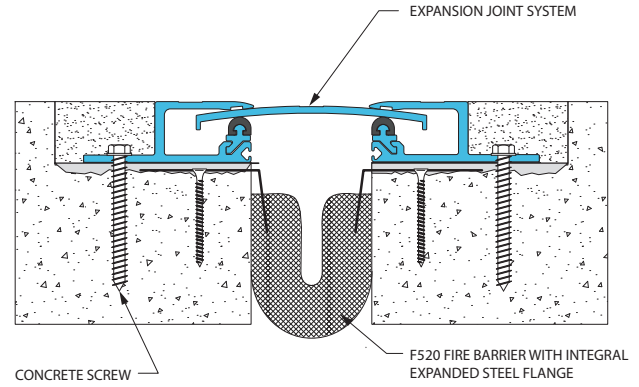

Inside (Recessed) Mount - Floor to Floor (430-A01-100 System Shown)

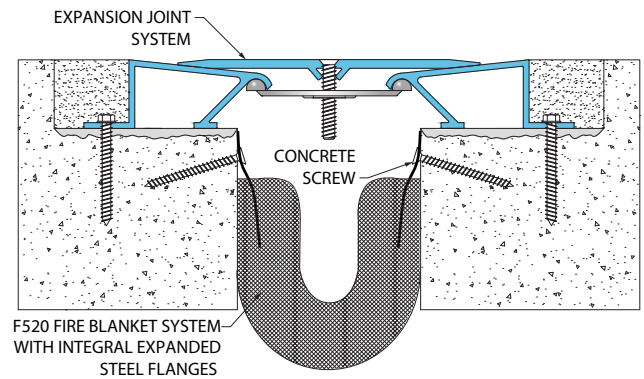

Bottom Mount - Floor to Floor (300-A01-100 System Shown)

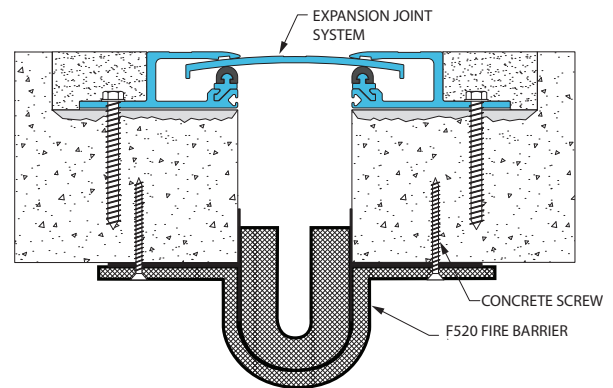

Fireline™ 520 Series

Fire Barrier Systems

Inside Mount "Water Guard" System - Roof to Roof
(651-A01 System Shown)

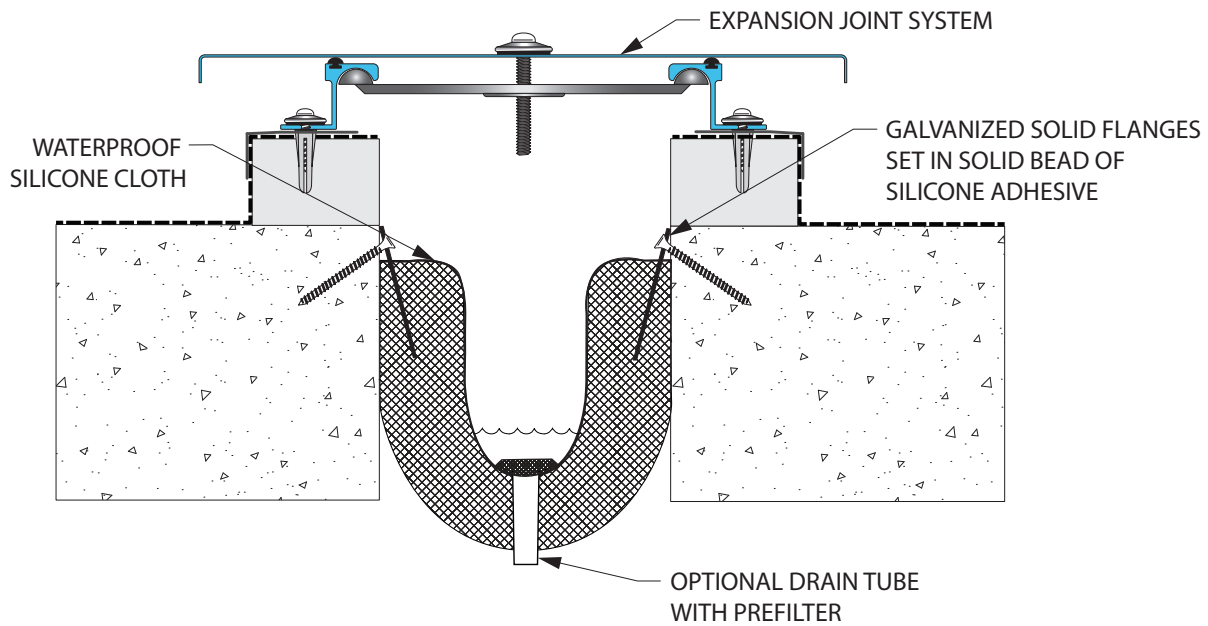

***NOTE:** Rated substrate hourly rating must not exceed the hourly rating of the F520 blanket assembly. Construction of the rated substrate is by others.