

940 Series

Handrail

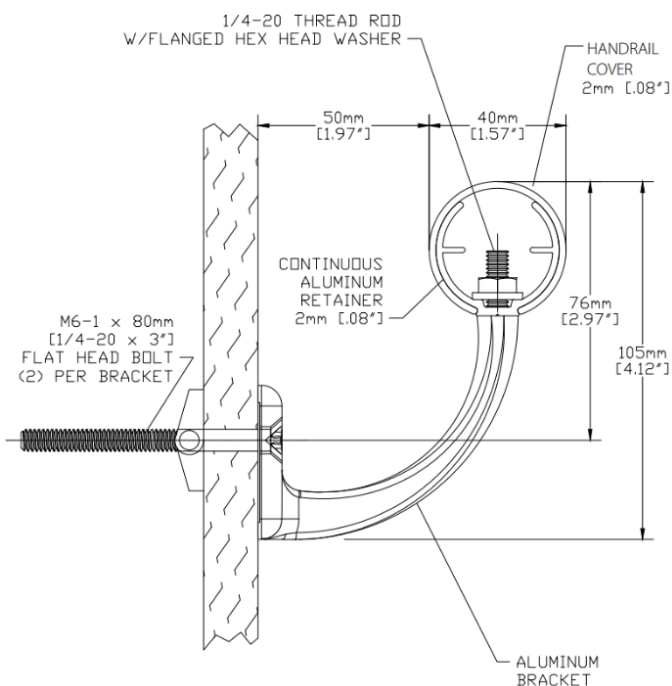

Bracket Options



- 40mm Round Handrail, extends 90mm from wall
- Cast Aluminium Bracket
- Smooth no texture vinyl cover, 2mm thick vinyl cover
- Also available in timber-look finish (940W). See image above(right).
- Black reveals for returns and corners
- Easy installation, clean-up and maintenance
- Meets ADA and ANSI criteria
- Manufactured in 3.66m (12') standard lengths
- All mounting fasteners are included with each order
- Meets the most rigorous standards and criteria of chemical emissions as prescribed by the GREENGUARD Environmental Institute
- Has been tested and meets GREENGUARD Environmental Institute's and the state of California's requirements for low emitting products as tested by Air Quality Sciences
- Has been tested and meets the GREENGUARD Children & School chemical emissions levels



940 Series

Handrail

PART 1 – GENERAL

1.01 SUMMARY

A. Handrail system for pedestrian safety and wall protection

1.02 SECTION INCLUDES

A. 940 Handrail System

1.03 REFERENCES

- A. American National Standards Institute (ANSI)
- B. American Society for Testing and Materials (ASTM)
- C. Americans with Disabilities Act (ADA)
- D. National Building Code of Canada (NBC)
- E. National Fire Protection Association (NFPA)
- F. Society of Automotive Engineers (SAE)
- G. Underwriters Laboratory (UL)
- H. Underwriters Laboratory of Canada (ULC)
- I. Uniform Building Code (UBC)

1.04 QUALITY ASSURANCE

A. Performance Requirements: Provide handrail systems that conform to the following requirements of regulatory agencies and the quality control of IPC Door and Wall Protection Systems, Inpro Corporation.

1. Fire Performance Characteristics: Provide UL Classified handrails conforming with NFPA Class A fire rating. Surface burning characteristics, as determined by UL-723 (ASTM E-84), shall be flame spread of 10 and smoke development of 350 - 450. Provide ULC (Canada) listed handrails conforming to the requirements of the National Building Code of Canada 2010, Subsection 3.1.13. Surface burning characteristics, as determined by CAN/ULC-S102.2, shall be flame spread of 15 and smoke developed of 35.
2. Self-Extinguishing: Provide handrails with a CC1 classification, as tested in accordance with the procedures specified in ASTM D-635-74, Standard Test Method for Rate of Burning and/or Extent and Time of Burning of Self-Supporting Plastics in a Horizontal Position, as referenced in UBC 52-4-1988.
3. Impact Strength: Provide rigid vinyl profile materials that have an Impact Strength of 30.2 ft-lbs/ inch of thickness as tested in accordance with the procedures specified in ASTM D-256-90b, Impact Resistance of Plastics.
4. Chemical and Stain Resistance: Provide handrails that show resistance to stain when tested in accordance with applicable provisions of ASTM D-543.
5. GREENGUARD Certified: Provide GREENGUARD Certified material. Profiles shall meet the requirements of GREENGUARD Certification Standards for Low-Emitting Products and GREENGUARD Product Emission Standard for Children & Schools.
6. Fungal and Bacterial Resistance: Provide rigid vinyl that does not support fungal or bacterial

growth as tested in accordance with ASTM G-21 and ASTM G-22.

7. Colour Consistency: Provide components matched in accordance with SAE J-1545 - (Delta E) with a colour difference no greater than 1.0 units using CIE Lab, CIE CMC, CIE LCh, Hunter Lab or similar colour space scale systems.

8. Code Compliance: Provide handrails that comply with all current ANSI and ADA requirements.

1.05 SUBMITTALS

- A. Product Data: Manufacturer's printed product data for each type of handrail specified.
- B. Detail Drawings: Mounting details with the appropriate fasteners for specific project substrates.
- C. Samples: Verification samples of handrail, 8" (203mm) long, in full size profiles of each type and colour indicated.
- D. Manufacturer's Installation Instruction: Printed installation instructions for each handrail.

1.06 DELIVERY, STORAGE AND HANDLING

- A. Deliver materials in unopened factory packaging to the jobsite
- B. Inspect materials at delivery to assure that specified products have been received.
- C. Store in original packaging in a climate-controlled location away from direct sunlight.

1.07 PROJECT CONDITIONS

A. Environmental Requirements: Products must be installed in an interior climate-controlled environment.

1.08 WARRANTY

A. Standard IPC Limited Lifetime Warranty against material and manufacturing defects.

PART 2 – PRODUCTS

2.01 SUPPLIER

A. Acculine Architectural Systems: 135-139 Northcorp Blvd, Broadmeadows VIC 3047, Telephone: (03) 9334 5911, www.acculine.com.au

2.02 MANUFACTURER

- A. Acceptable Manufacturer: IPC Door and Wall Protection Systems, Inpro Corporation, PO Box 406 Muskego, WI 53150 USA; Telephone: 800.222.5556, Fax: 888.715.8407, Internet address: <http://www.inprocorp.com>
- B. Substitutions: Not permitted
- C. Provide all handrails and wall protection from a single source.

2.03 MANUFACTURED UNITS

- A. Handrail Profile
 1. 940 Handrail, 40mm (1.57") gripping diameter, extends 90mm (3.54") from wall.Options: Curved handrail, specify radius. Minimum radius - .91m (3')

2.04 MATERIALS

A. Vinyl: Snap-on covers of 2mm thickness shall be extruded from chemical and stain resistant unplasticized polyvinyl chloride (uPVC) with the addition of impact modifiers. No plasticizers shall

be added (plasticizers may aid in bacterial growth). Accent strips when used shall be of polyvinyl chloride.

B. Aluminium: Continuous aluminium retainer of 2mm (.080") thickness shall be fabricated from 6063-T5 aluminium, with a mill finish.

C. Cast aluminium brackets shall be made of type ADC12 Aluminium.

2.05 COMPONENTS

- A. Returns, inside corners, outside corners and reveals shall be made of injection moulded thermoplastics.
- B. Fasteners: All mounting systems accessories appropriate for substrates indicated on the drawings shall be provided, unless installer supplied is indicated.

2.06 FINISHES

- A. Vinyl Covers: Handrail colours to be selected by the architect from the IPC finish selection. Surface shall have a smooth finish.
- B. Moulded components: Inside corners, outside corners and returns shall be of a colour matching the handrails. Surface shall have a smooth finish.
- C. Moulded reveals shall have a smooth finish and shall be black.
- D. Aluminium: Cast aluminium bracket shall have a clear anodized finish.

PART 3 – EXECUTION

3.01 EXAMINATION

- A. Examine areas and conditions in which the handrail systems will be installed.
 1. Complete all finishing operations, including painting, before beginning installation of handrail system materials.
- B. Wall surface shall be dry and free from dirt, grease and loose paint.

3.02 PREPARATION

A. General: Prior to installation, clean substrate to remove dust, debris and loose particles.

3.03 INSTALLATION

A. General: Locate the handrail as indicated on the approved detail drawing for the appropriate substrate and in compliance with the IPC installation instructions. Install handrail level and plumb at the height indicated on the drawings.

3.04 CLEANING

A. At completion of the installation, clean surfaces in accordance with the IPC clean-up and maintenance instructions.

