

Tape-On

Corner Guards

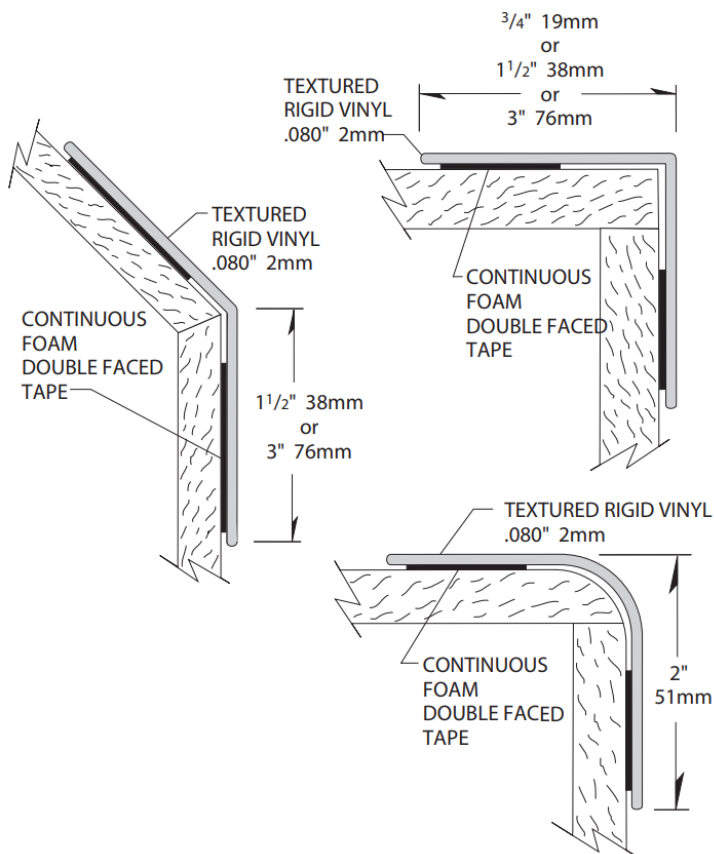

- Available in 90°, 90° bullnose and 135° styles
- 2mm thick scratch and stain resistant rigid vinyl
- Manufactured in 1220mm (4'), 2440mm (8'), 2740mm (9') and 3660mm (12') standard heights. Can be cut to any height
- Standard with factory applied double faced foam tape. Available without tape to be applied with optional field applied heavy duty adhesive.
- Available in standard solid colours, Woodlands, Faux metal and Elements patterns
- Stocked in 50x50mm wing size. Also available in 75x75mm, 38x38mm and 19x19mm
- Meets the most rigorous standards and criteria of chemical emissions as prescribed by the GREENGUARD Environmental Institute
- Has been tested and meets GREENGUARD Environmental Institute's and the state of California's requirements for low emitting products as tested by Air Quality Sciences
- Has been tested and meets the GREENGUARD Children & School chemical emissions levels

Tape-On Corner Guards

PART 1 – GENERAL

1.01 SUMMARY

A. Corner guard system for wall protection

1.02 SECTION INCLUDES

A. Tape-on Corner Guard

1.03 REFERENCES

- A. American Society for Testing and Materials (ASTM)
- B. National Building Code of Canada (NBC)
- C. National Fire Protection Association (NFPA)
- D. Society of Automotive Engineers (SAE)
- E. Underwriters Laboratory (UL)
- F. Underwriters Laboratory of Canada (ULC)
- G. Uniform Building Code (UBC)

1.04 SYSTEM DESCRIPTION

A. Performance Requirements: Provide corner guard systems that conform to the following requirements of regulatory agencies and the quality control of IPC Door and Wall Protection Systems, InPro Corporation.

1. Fire Performance Characteristics: Provide UL Classified corner guards conforming with NFPA Class A fire rating. Surface burning characteristics, as determined by UL-723 (ASTM E-84), shall be flame spread of 10 and smoke development of 350 - 450. Provide ULC (Canada) listed corner guards conforming to the requirements of the National Building Code of Canada 2010, Subsection 3.1.13. Surface burning characteristics, as determined by CAN/ULC-S102.2, shall be flame spread of 15 and smoke developed of 35.
2. Self-Extinguishing: Provide corner guards with a CC1 classification, as tested in accordance with the procedures specified in ASTM D-635-74, Standard Test Method for Rate of Burning and/or Extent and Time of Burning of Self-Supporting Plastics in a Horizontal Position, as referenced in UBC 52-4-1988.
3. Impact Strength: Provide rigid vinyl profile materials that have an Impact Strength of 30.2 ft-lbs/inch of thickness as tested in accordance with the procedures specified in ASTM D-256-90b, Impact Resistance of Plastics.
4. Chemical and Stain Resistance: Provide corner guards that show resistance to stain when tested in accordance with applicable provisions of ASTM D-543.
5. GREENGUARD Certified: Provide GREENGUARD Certified material. Profiles shall meet the requirements of GREENGUARD Certification Standards for Low-Emitting Products and GREENGUARD Product Emission Standard for Children & Schools.
6. Fungal and Bacterial Resistance: Provide rigid vinyl that does not support fungal or bacterial growth as tested in accordance with ASTM G-21 and ASTM G-22.
7. Colour Consistency: Provide components matched in accordance with SAE J-1545 - (Delta E) with a colour difference no greater than 1.0 units using CIE Lab, CIE CMC, CIE LCh, Hunter Lab or similar colour space scale systems.

1.05 SUBMITTALS

A. Product Data: Manufacturer's printed product data for each type of corner guard specified.

B. Detail Drawings: Mounting details with the appropriate adhesives for specific project substrates.

C. Samples: Verification samples of corner guard, 203mm long, in full size profiles of each type and colour indicated.

D. Manufacturer's Installation Instruction: Printed installation instructions for each corner guard.

1.06 DELIVERY, STORAGE AND HANDLING

- A. Deliver materials in unopened factory packaging to the jobsite
- B. Inspect materials at delivery to assure that specified products have been received.
- C. Store in original packaging in a climate-controlled location away from direct sunlight.

1.07 PROJECT CONDITIONS

A. Environmental Requirements: Products must be installed in an interior climate-controlled environment.

1.08 WARRANTY

A. Standard IPC Limited Lifetime Warranty against material and manufacturing defects.

PART 2 – PRODUCTS

2.01 SUPPLIER

A. Acculine Architectural Systems: 135-139 Northcorp Blvd, Broadmeadows VIC 3047, Telephone: (03) 9334 5911, www.acculine.com.au

2.02 MANUFACTURER

- A. Acceptable Manufacturer: IPC Door and Wall Protection Systems, InPro Corporation, PO Box 406 Muskego, WI 53150 USA; Telephone: 800.222.5556, Fax: 888.715.8407, www.inprocorp.com
- B. Substitutions: Not permitted
- C. Provide all corner guards and wall protection from a single source.

2.03 MANUFACTURED UNITS

- A. Corner Guard Profile
 1. Tape-on Corner Guards
 - 19mm x 19mm – 90°
 - 38mm x 38mm – 90°
 - 38mm x 38mm – 135°
 - 76mm x 76mm – 90°
 - 76mm x 76mm – 135°
- Standard heights: 1220mm, 2440mm, 2740mm and 3660mm
Custom heights available

2.04 MATERIALS

A. Vinyl: Corner guard of 2mm thickness shall be extruded from chemical and stain resistant polyvinyl chloride with the addition of impact modifiers. No plasticizers shall be added (plasticizers may aid in bacterial growth).

2.05 COMPONENTS

- A. Attachments
 1. Tape: Factory applied double faced foam tape.
 2. Adhesive: Field applied heavy duty adhesive.

2.05 FINISHES

A. Vinyl: Colours of the corner guard to be selected by the architect from the IPC finish selection. Surface shall have a pebblette texture.

PART 3 – EXECUTION

3.01 EXAMINATION

A. Examine areas and conditions in which the corner guard systems will be installed.

1. Complete all finishing operations, including painting, before beginning installation of corner guard system materials.
- B. Wall surface shall be dry and free from dirt, grease and loose paint.

3.02 PREPARATION

A. General: Prior to installation, clean substrate to remove dust, debris and loose particles.

3.03 INSTALLATION

- A. General: Locate the corner guard as indicated on the approved detail drawing for the appropriate substrate and in compliance with the IPC installation instructions. Install corner guard level and plumb at the height indicated on the drawings.
- B. Installation of Tape-on Corner Guards:
 1. Surface must be clean, dry and properly sealed.
 2. Installation with factory applied foam tape - Remove release paper from the foam tape.
 3. Installation with Heavy Duty Adhesive - Cut the smallest opening possible in the spout. Apply a continuous bead of adhesive on each wing of the corner guard.
 4. Position the corner guard on the substrate corner.
 5. Starting at the bottom, press into place, working upward until entire corner guard is in place.
 6. Roll surface with IPC Extension Roller.

3.04 CLEANING

A. At completion of the installation, clean surfaces in accordance with the IPC clean-up and maintenance instructions.