

# Flexible

## Corner Guards

---

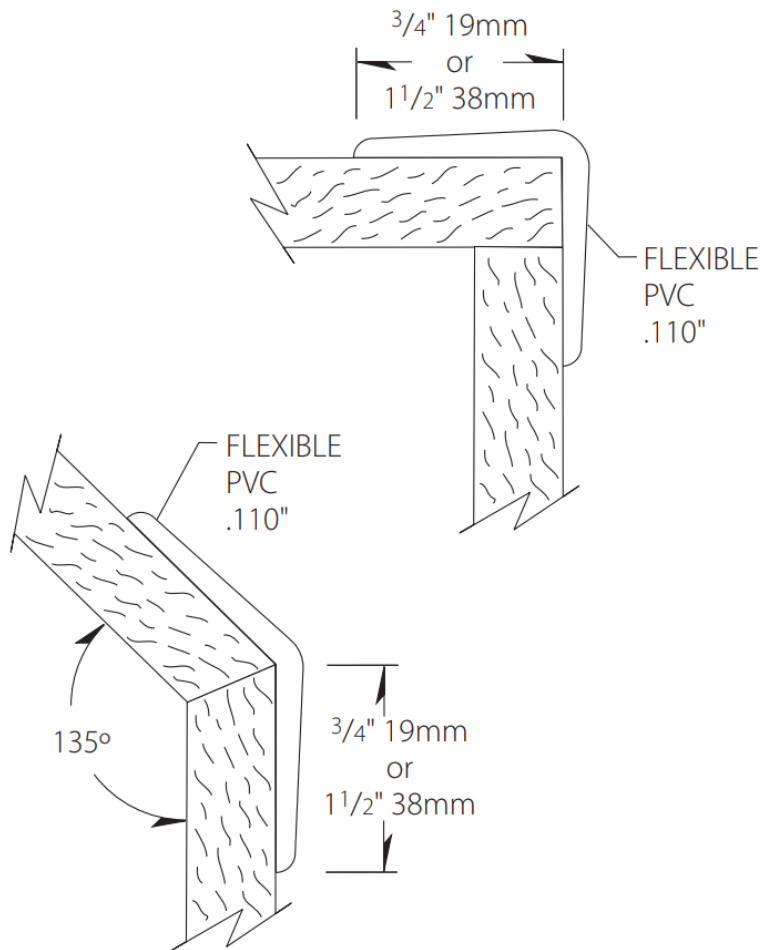

- Available in 19mm or 38mm wing sizes and 90° and 135° styles
- Made with Biopolymer Flex PVC
- 2.8mm thick flexible vinyl
- Smooth, satin finish
- Allows for a  $\pm 10^\circ$  adjustment
- Manufactured in 0.91m, 1.22m, 2.44m, 2.74m and 3.66m standard heights
- Installed with heavy duty adhesive

# Flexible Corner Guards

## PART 1 - GENERAL

### 1.01 SUMMARY

A. Corner guard system for wall protection

### 1.02 SECTION INCLUDES

A. Flexible Corner Guards

### 1.03 REFERENCES

A. American Society for Testing and Materials (ASTM)

B. National Fire Protection Association (NFPA)

C. Society of Automotive Engineers (SAE)

### 1.04 SYSTEM DESCRIPTION

A. Performance Requirements: Provide corner guard systems that conform to the following requirements of regulatory agencies and the quality control of IPC Door and Wall Protection Systems, InPro Corporation.

1. Fire Performance Characteristics: Provide corner guards conforming with NFPA Class B fire rating. Surface burning characteristics, as determined by ASTM E-84, shall be flame spread of 55 and smoke development of 375.

2. Colour Consistency: Provide components matched in accordance with SAE J-1545 - (Delta E) with a colour difference no greater than 1.0 units using CIE Lab, CIE CMC, CIE LCh, Hunter Lab or similar colour space scale systems.

### 1.05 SUBMITTALS

A. Product Data: Manufacturer's printed product data for each type of corner guard specified.

B. Detail Drawings: Mounting details with the appropriate adhesives for specific project substrates.

C. Samples: Verification samples of corner guard, 203mm long, in full size profiles of each type and colour indicated.

D. Manufacturer's Installation Instruction: Printed installation instructions for each corner guard.

### 1.06 DELIVERY, STORAGE AND HANDLING

A. Deliver materials in unopened factory packaging to the jobsite

B. Inspect materials at delivery to assure that specified products have been received.

C. Store in original packaging in a climate-controlled location away from direct sunlight.

### 1.07 PROJECT CONDITIONS

A. Environmental Requirements: Products must be installed in an interior climate-controlled environment.

### 1.08 WARRANTY

A. Standard IPC Limited Lifetime Warranty against material and manufacturing defects.

## PART 2 - PRODUCTS

### 2.01 SUPPLIER

A. Acculine Architectural Systems: 135-139 Northcorp Blvd, Broadmeadows VIC 3047, Telephone: (03) 9334 5911, www.acculine.com.au

### 2.02 MANUFACTURER

A. Acceptable Manufacturer: IPC Door and Wall Protection Systems, InPro Corporation, PO Box 406 Muskego, WI 53150 USA; Telephone: 800.222.5556, Fax: 888.715.8407, www.inprocorp.com

B. Substitutions: Not permitted

C. Provide all corner guards and wall protection from a single source.

### 2.03 MANUFACTURED UNITS

A. Corner Guard Profile

1. Flexible Corner Guards

3436F, 19mm x 19mm x 914mm, 90°

3448F, 19mm x 19mm x 1220mm, 90°

3496F, 19mm x 19mm x 2440mm, 90°

3409F, 19mm x 19mm x 2740mm, 90°

3412F, 19mm x 19mm x 3660mm, 90°

436135F, 19mm x 19mm x 914mm, 135°

448135F, 19mm x 19mm x 1220mm, 135°

496135F, 19mm x 19mm x 2440mm, 135°

409135F, 19mm x 19mm x 2740mm, 135°

412135F, 19mm x 19mm x 3660mm, 135°

11236F, 38mm x 38mm x 914mm, 90°

11248F, 38mm x 38mm x 1220mm, 90°

11296F, 38mm x 38mm x 2440mm, 90°

11209F, 38mm x 38mm x 2740mm, 90°

11212F, 38mm x 38mm x 3660mm, 90°

236135F, 38mm x 38mm x 914mm, 135°

248135F, 38mm x 38mm x 1220mm, 135°

296135F, 38mm x 38mm x 2440mm, 135°

209135F, 38mm x 38mm x 2740mm, 135°

212135F, 38mm x 38mm x 3660mm, 135°

Standard heights: 0.91m, 1.22m, 2.44m and 2.74m

Custom heights available

### 2.04 MATERIALS

A. Vinyl: Corner guard of 2.8mm thickness shall be extruded from chemical and stain resistant Biopolymer Flex PVC.

### 2.05 COMPONENTS

A. Attachments

1. Adhesive: Field applied heavy-duty adhesive.

### 2.06 FINISHES

A. Vinyl: Colours of the corner guard to be selected by the architect from the IPC finish selection. Surface shall be smooth.

## PART 3 - EXECUTION

### 3.01 EXAMINATION

A. Examine areas and conditions in which the corner guard systems will be installed.

1. Complete all finishing operations, including painting, before beginning installation of corner guard system materials.

B. Wall surface shall be dry and free from dirt, grease and loose paint.

### 3.02 PREPARATION

A. General: Prior to installation, clean substrate to remove dust, debris and loose particles.

### 3.03 INSTALLATION

A. General: Locate the corner guard as indicated on the approved detail drawing for the appropriate substrate and in compliance with the IPC installation instructions.

Install corner guard level and plumb at the height indicated on the drawings.

B. Installation of Flexible Corner Guards: Material must be stored, installed and used in environmentally controlled conditions

1. Allow the corner guards to reach room temperature before installing. The wall surface that the corner guards are to be applied must be dry and free of dirt, dust, oil, loose paint, wax and

grease. 3660mm corner guards may be folded for shipment via UPS. Allow the corner guards to lie flat for 24 hours before installation. Additional bracing may be required during installation to insure complete contact with the wall.

2. Use IPC #535 Heavy-Duty Adhesive to adhere corner guards.

a. Apply a bead of IPC #535 Heavy-Duty Adhesive in a zig zag pattern over the back of the corner guard.

b. Immediately position the corner guard on the wall and apply pressure until a tight fit is achieved. An extension roller will aid this step.

Adhesive coverage: One 10.6 oz. Cartridge of #535 Heavy-Duty Adhesive will adhere the following corner guards based on an approximate coverage of 70 lf per cartridge.

Model# Number of Corner Guards per cartridge

3436F, 436135F, 11236F, 236135F - 11

3448F, 448135F, 11248F, 248135F - 8

3496F, 496135F, 11296F, 296135F - 4

3409F, 409135F, 11209F, 209135F - 3

3412F, 412135F, 11212F, 212135F - 3

### 3.04 CLEANING

A. At completion of the installation, clean surfaces in accordance with the IPC clean-up and maintenance instructions.