

# Installation Instructions

## Palladium Rigid Vinyl Wall Sheet/Rub Strip

### Important

#### Storage

**Flat sheet** - Store Palladium® Rigid Sheet in a clean, dry, interior area at temperatures between 10°-35°C. Keep out of direct sunlight. Make sure sheet is well supported.

- Store in a clean, dry, interior area
- Avoid direct sunlight
- Store between 10°-35°C

**Rolled Sheet** – Unroll sheet material immediately upon receipt and store in clean, dry, interior area at temperatures between 10°-35°C. Keep out of direct sunlight. If the rolled material does not lay flat, reverse roll the sheet until it does lay flat. Make sure sheet is well supported. Keep sheet length to a maximum of 3660mm. When installing rolled sheet, follow the non-porous installation instructions.

- Unroll rolled sheet immediately
- Reverse roll material until it lays completely flat.
- Store in a clean, dry, interior area
- Avoid direct sunlight.
- Store between 10°-35° C.
- Keep sheet length to a maximum of 3660mm
- For rolled sheet, follow non-porous installation steps.

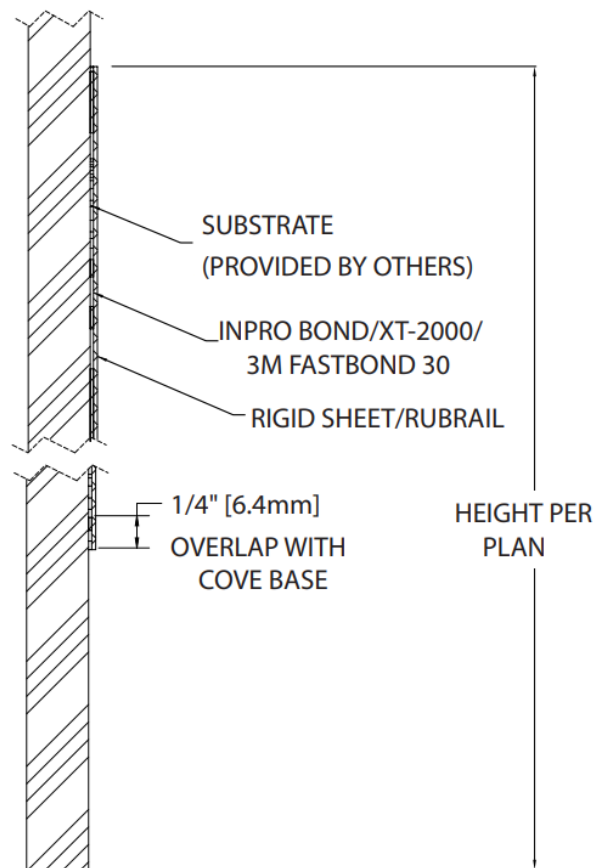

#### Acclimate

24 hours before the installation, acclimate the sheet material and adhesive in the environmentally controlled area where it will be installed. This area requires a temperature between 18°-27°C and a humidity level less than 80%. Maintain a constant temperature between 18°-27°C and a constant humidity level less than 80% in the installation area 24 hours before installation, during the entire installation and 48 hours after the installation.

- Acclimate sheet and adhesives in the environmentally controlled installation area.
- Acclimate sheet and adhesives at temperatures between 18°-27°C.
- Acclimate sheet and adhesives at humidity less than 80%.
- Maintain a constant temperature and humidity 24 hours before, during and 48 hours after installation.

#### Recommended Tools

Paint/Primer (if needed), Chalk Line or Laser Level, Level, InPro #545 Trowel, 4mm] V-notches with 13mm spacing between notches, Recommended Adhesive – InPro Bond, XT-2000+ or 3M Fastbond 30, Smooth foam paint roller (for contact cement), Straight Edge, Utility knife with extra blades, Painter Tape, InPro #333, Extension Roller, 9" 229mm wide, clean cloths, Water

# Installation Instructions

## Palladium Rigid Vinyl Wall Sheet/Rub Strip

---



407A  
OPTIONAL  
ALUMINUM  
TOP CAP



409A  
OPTIONAL  
ALUMINUM  
INSIDE  
CORNER



408A  
OPTIONAL  
ALUMINUM  
VERTICAL  
DIVIDER



420A  
OPTIONAL  
ALUMINUM  
CORNER  
GUARD

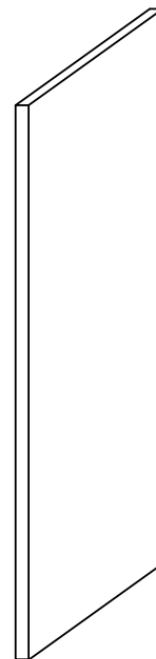

PALLADIUM® RIGID  
SHEET



407  
TOP CAP



409  
INSIDE  
CORNER



408  
VERTICAL  
DIVIDER



TAPE-ON  
CORNER  
GUARD



INPRO #545  
TROWEL

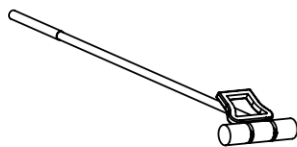

INPRO #333  
EXTENSION ROLLER

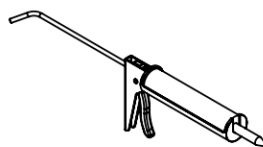

COLOR MATCH CAULK  
(OPTIONAL)



INPRO BOND,  
XT-2000+, OR  
3M FASTBOND 30

# Installation Instructions

## Palladium Rigid Vinyl Wall Sheet/Rub Strip

---

### Wall Preparation

Walls must be free from dirt, grease and loose paint. Remove any coatings designed to improve clean-up since these coatings may affect adhesion. Glossy surfaces may require sanding or priming to help promote adhesion. Do not install sheet if the moisture content of the drywall is greater than 4%.

**New drywall or plaster** – Walls must be smooth and wiped clean to remove dust. Seal or prime walls with paint or primer that does not contain Polyvinyl Acetate (PVAc). Allow paint/primer to dry in accordance with the manufacturer's application instructions.

- Remove Dust and Dirt
- Seal walls with paint/primer.
- DO NOT use paint/primer that contains Polyvinyl Acetate (PVAc)

**Painted Drywall or Plaster** - Test painted walls for adhesion by applying a 305mm x 305mm pieces of Palladium® Rigid Sheet in an inconspicuous area. Allow the test sheet to remain adhered for 24 hours. Remove test sheet, if paint has softened, strip the paint off the wall and reseal with a recommended paint/primer.

- Test the wall to make sure paint is compatible with adhesive.
- Strip the paint off wall if adhesives softens paint after testing.

**Concrete and Concrete Masonry Units** – Fill surface of concrete walls with an appropriate filler to make it smooth. Seal or prime walls with paint or primer that does not contain Polyvinyl Acetate (PVAc). Allow paint/primer to dry in accordance with the manufacturer's application instructions. Unfilled grout lines may telegraph through the sheet, especially with thinner sheet thicknesses.

- Fill concrete to make smooth.
- Seal concrete with paint/primer.
- DO NOT use paint/primer that contains Polyvinyl Acetate (PVAc)

**Non-Porous Substrates** - Some non-porous substrates include metal, ceramic tile, high-pressure laminate, epoxy painted walls, vinyl wall covering (VWC) and rigid sheet. InPro Bond and XT-2000+ adhesives can be used to apply rigid sheet to securely adhered vinyl wallcovering or rigid sheet and other non-porous substrates. Adhering rigid sheet over existing sheet or VWC will increase smoke generation and flame spread and negate the Group 1 fire rating. If you choose to do this, follow the non-porous installation instructions.

# Installation Instructions

## Palladium Rigid Vinyl Wall Sheet/Rub Strip

### Cutting and Dry Fitting Sheets

When handling sheet be careful and avoid kinking the sheet. Layout sheet location on the wall marking plumb lines and level lines where needed. When laying out sheet allow a 2mm gap between sheet material and ceilings, floors, corners, door casings, window casings and between sheets. Do not install cove base directly over rigid vinyl sheet, vinyl wallcovering, ceramic tile, metal or other non-porous surfaces. Overlap these materials with the cove base by 7mm. See Figure 1. Cut sheet material with a metal straight edge and a sharp utility knife. Cut the sheet using multiple passes. Cut openings in the sheet for outlets and other objects located on the wall. Dry fit the sheet to the wall by holding it in place on the wall. When installing multiple sheets in an area, dry fit all sections. Do not install sheet material too close to heat registers, radiators and other equipment that may produce excessive heat. Sheet installation in these areas may cause de-lamination or bubbling of the sheet

- DO NOT kink the sheet when handling.
- Mark plumb lines and level lines on wall.
- Allow 2mm between sheet and ceilings, floors, walls, casings and other sheets.
- Do NOT install cove base directly over rigid sheet; Overlap sheet with cove base by 7mm.
- Use a straight edge and sharp utility knife to cut sheet material.
- Cut sheet using multiple passes with the utility knife.
- DO NOT install sheet too close to heat sources.
- Dry fit the sheet to the wall.

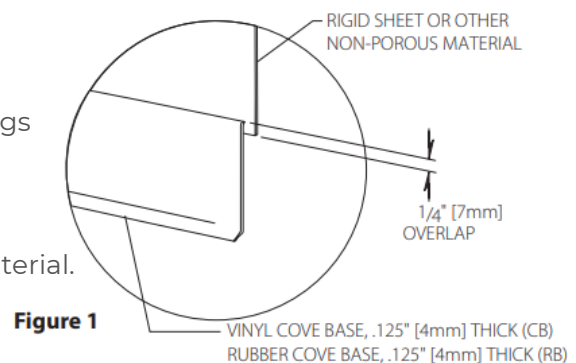

Adhesive Application InPro Bond/XT-2000+ Apply adhesive only to the wall surface. Do not apply adhesive to the back of the sheet. After adhesive is applied, it will need to cure before applying the sheet. Application temperature: After following the steps to acclimate the materials, maintain a constant temperature between 18°-27°C with an indoor humidity level below 80%. Use a 4mm x 4mm V-notched trowel with 13mm spaces between the V-grooves to apply adhesive (see figure 2). Apply adhesive to the entire area where the sheet is to be installed. Remove any excess adhesive from unwanted surfaces with a damp cloth before the adhesive has cured. Cured adhesive is nearly impossible to remove. Do not let adhesive dry in the notches of the trowel. This will change the application rate of the trowel. Application rate is 3.68m<sup>2</sup>/L with InPro Trowel #545.

- Allow materials to acclimate following the recommendations stated earlier.
- For 1mm, 1.5mm and 2mm thick sheet use:
  - V-notched side of trowel with 4mm x 4mm.
  - V-notches spaced 13mm apart. (InPro item #545)
- For 0.8mm thick sheet use:
  - Square notched side of trowel with 4mm x 4mm
  - Square spaced 13mm apart. (InPro item #545)
- Apply adhesive only on wall.
- Apply adhesive to the entire wall area where sheet will be installed.
- Remove any excess adhesive before it has cured.
- Clean trowel so notches do not get clogged.
- Application rate is 3.68m<sup>2</sup>/L using V-notched side and 2.95m<sup>2</sup>/L using Square notched side with InPro Trowel #545.

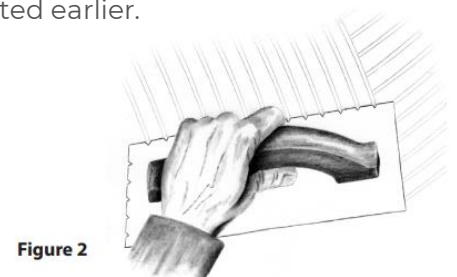

# Installation Instructions

## Palladium Rigid Vinyl Wall Sheet/Rub Strip

---

### **Adhesive Curing, Porous Substrate**

Temperature and humidity levels will affect the time it takes for adhesive to cure. Under ideal conditions cure time should be 45-60 minutes. It could be significantly longer, but not more than 3 hours. When first applied the adhesive is white. As it cures, it becomes translucent and tacky. Install the sheet material when 60-75% of the adhesive has become translucent or when it becomes tacky and does not transfer to your finger. Fans will increase air movement and reduce cure time. The installer is responsible for determining the cure time of the adhesive, based on job site conditions. Do a test installation if needed.

- Adjust cure time for temperature and humidity level.
- Allow adhesive to become 60-75% translucent or let adhesive become tacky and not transfer to your finger when touched.
- Use fans to reduce cure time.
- The installer is responsible for determining the cure time of the adhesive, based on job site conditions.
- Do a test installation, if needed.

### **Adhesive Curing, Non-Porous Substrate (follow these steps for rolled sheet)**

Some non-porous substrates include metal, ceramic tile, high-pressure laminate, epoxy painted walls, and vinyl wall covering. When applying adhesives to these substrates, moisture in the adhesive will not be absorbed by the substrate. Longer cure times are required. Allow the adhesive to become 90% translucent. Let the adhesive become tacky and not transfer to your finger when touched. Temperature and humidity levels will affect the time it takes for adhesive to cure. Cure times may range from 1 hour but not more than 3 hours. Fans will increase air movement and reduce cure time. The installer is responsible for determining the cure time of the adhesive, based on job site conditions. Do a test installation if needed. Align the sheet perfectly, since the longer cure time makes the adhesive behave like contact cement. Readjusting the sheet may be difficult or impossible.

- Allow adhesive to cure longer (at least an hour but not more than three hours)
- Allow the adhesive to become 90% translucent and let adhesive become tacky and not transfer to your finger when touched.
- Use fans to reduce cure time.
- The installer is responsible for determining the cure time of the adhesive, based on job site conditions.
- Do a test installation, if needed.
- Position the sheet perfectly, since adhesive behaves like contact cement.

# Installation Instructions

## Palladium Rigid Vinyl Wall Sheet/Rub Strip

**Figure 3**

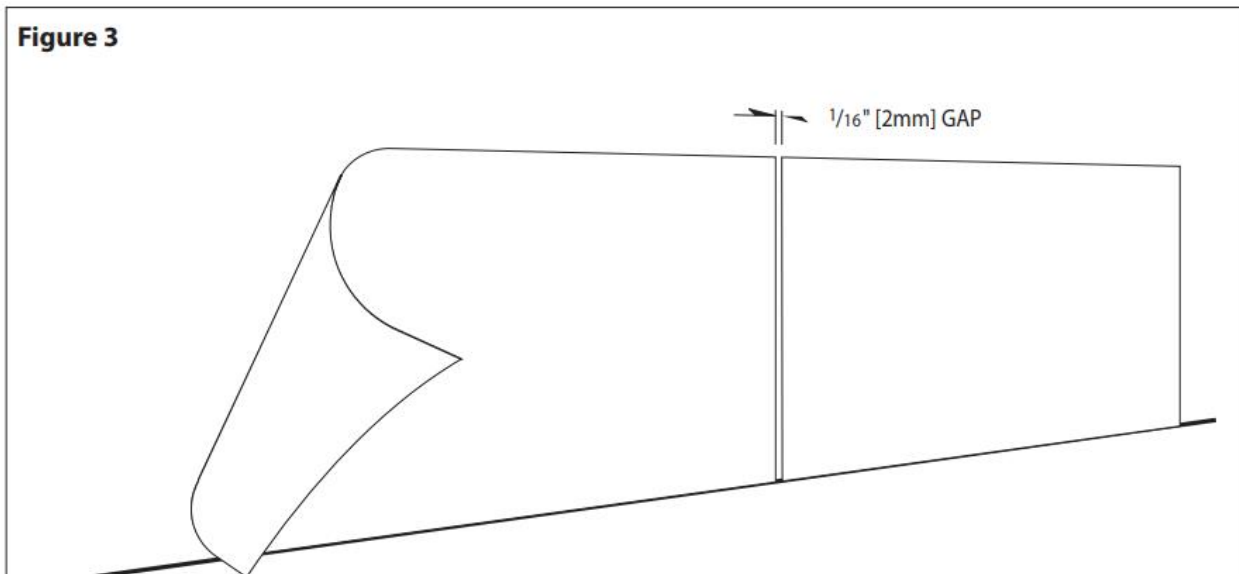

**Figure 4**

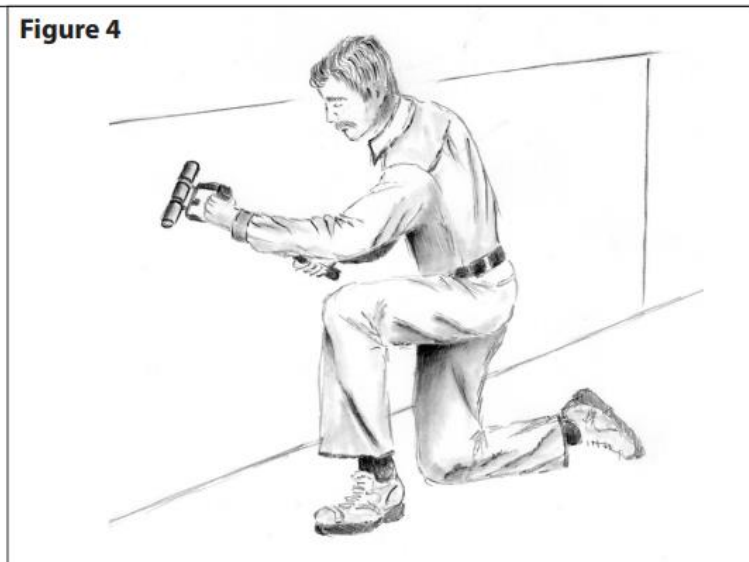

### Positioning Sheet

Wipe the back of the sheet to remove any dust. After the adhesive has cured, position the sheet on the wall aligning the edges with plumb lines or level lines. Hold sheets back from ceiling, floors, corners, casings and other sheets by 2mm to allow for expansion (see figure 3). If needed reposition the sheet on the wall by carefully pulling it back and re-aligning it to the wall. Use an extension roller (InPro item # 333) to firmly embed the sheet into the adhesive (see figure 4). Apply heavy body pressure to every square inch of sheet, starting at the centre and working to the edges, making sure it is bonded securely to the wall.

- Wipe the back of sheet to remove dust.
- Position sheet on wall
- Allow 2mm gaps for expansion.
- Reposition sheet before rolling if needed.
- Roll entire sheet with extension roller, starting at the centre and working to the edges

# Installation Instructions

## Palladium Rigid Vinyl Wall Sheet/Rub Strip

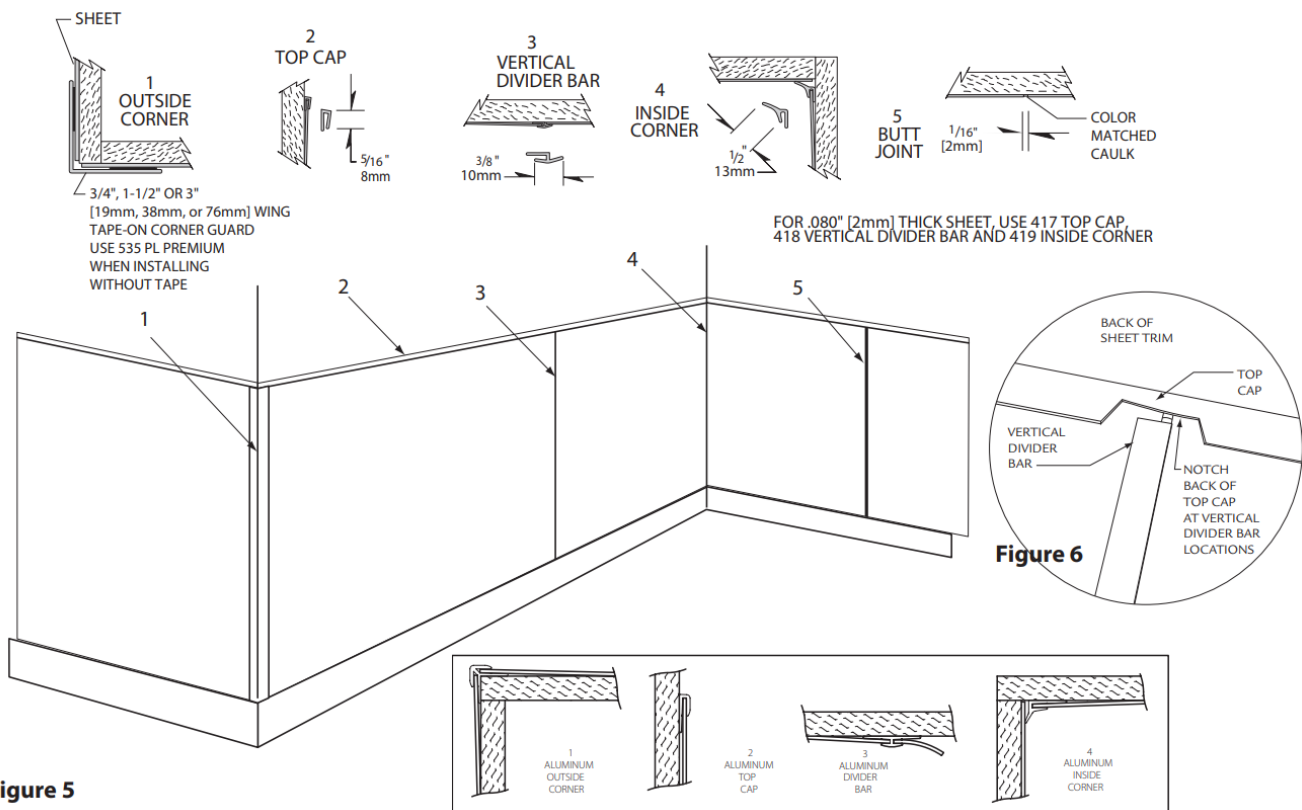

### Trim Pieces (see figure 5)

If using trim pieces with an InPro Bond or XT-2000 installation, install the first sheet on the wall. Cut trim pieces with a metal straight edge and sharp utility knife. Slide vertical divider bars or inside corners on the next sheet to be installed. Overlap the edge of the sheet on the wall with the divider bar or inside corner. With aluminium divider bars, slide sheet into the divider bar. When using top caps and vertical divider bars, notch the back of the top cap where it intersects with the divider bar (see figure 6). Install the top cap by sliding it on the top edge of the sheet after the sheet is in place. Roll all trim pieces and the entire sheet with an extension roller (InPro item # 333). Stainless Steel Trim - Cut stainless steel trim with a hack saw or similar. Tape exposed surfaces with painters' tape to help protect it when cutting.

- Cut trim pieces with a sharp utility knife.
- Overlap trim piece over the first sheet installed.
- Notch the back of the top cap where it intersects the vertical divider bar.
- Slide top cap on edge of sheet after sheet is on wall.
- Roll all trim pieces and entire sheet with extension roller.
- Cut stainless steel trim with a hack saw or similar

# Installation Instructions

## Palladium Rigid Vinyl Wall Sheet/Rub Strip

---

### Contact Cement Application

Apply 3M Fastbond 30 Contact Cement to the back of the sheet and on the wall with a smooth foam paint roller or brush. Let the contact cement completely dry on both surfaces. Contact cement should not transfer to your hand when touched. If areas remain wet, adhesion problems will occur. Drying time will vary depending on the temperature and the humidity level. Drying time can be as little as ½-hour but could be significantly longer depending on conditions. Once the contact cement is dry, apply the sheet to the wall within 4 hours. If using trim pieces, cut and slide them on the sheet before coating the back of the sheet with contact cement. Remove any excess contact cement with a water dampened cloth before the contact cement dries.

- Apply contact cement to the back of sheet and the wall
- Let both surfaces completely dry.
- Adjust drying time for the jobsite conditions.
- Once dry apply the sheet to the wall within 4 hours.
- If using trim pieces slide them on the back of sheet before coating with contact cement. • Remove excess contact cement before it dries.
- Coverage – 16.68m<sup>2</sup>/L

### Positioning Sheet (Contact Cement)

Carefully position the sheet on the wall, by aligning the edges of the sheet to the level/plumb lines. Hold sheets back from ceilings, floors, corners, casings and other sheets by 2mm to allow for expansion. Do not install cove base directly over rigid vinyl sheet, vinyl wallcovering, ceramic tile, metal or other non-porous surfaces. Overlap these materials with the cove base by 7mm. Once the sheet makes contact with the wall it will be permanently bonded. Repositioning the sheet will be impossible without damaging the sheet and/or the wall. The use of “paper slip sheets” between the rigid sheet material and the wall may help with the positioning of sheet material. After positioned, roll all trim pieces and the entire sheet with an extension roller (InPro item # 333). Start at the centre and work to the edges of the sheet.

- Carefully position sheet to wall.
- Use “Slip Sheets” to help position sheet material.
- Allow 2mm gaps for expansion.
- Do NOT install cove base directly over rigid sheet; overlap sheet with cove base by 7mm
- Roll trim pieces and the entire sheet with an extension roller, starting at the centre and working to the edges.

### Colour Matched Caulk

Use Colour Matched Caulk to fill in the joints between sheets. Apply masking tape along both edges of the joint. Cut the spout on the tube at a 45° angle. Apply the colour matched caulk to the joint. With a putty knife or finger, remove excess caulk from the joint. Immediately after applying the caulk remove the painter’s tape. If sinking occurs, reapply Colour Matched Caulk following the same steps. Remove unwanted caulk, before it cures, with a water dampened cloth.

- Apply masking tape on the edges of the joint.
- Apply caulk to joint and remove excess with putty knife or finger.
- Remove painters’ tape before caulk cures.
- Repeat caulk application if sinking occurs.
- Remove unwanted caulk before it cures



# Installation Instructions

## Palladium Rigid Vinyl Wall Sheet/Rub Strip

---

### Clean-up

Completion: Immediately upon completion of installation, clean sheet and remove layout marks excess adhesive and surface blemishes. Cured adhesive is difficult to remove. Use mineral spirits and rub gently with a soft cloth. After adhesive is removed, wipe the area with a general-purpose cleaner. Rinse the area with a water dampened cloth. Dry with a clean, soft cloth.

- Upon Completion, remove layout marks, excess adhesive and surface blemishes.
- Cured Adhesive.
- Use mineral spirits and gently rub.
- Follow by wiping with a cleaner.
- Rinse sheet with water dampened cloth.

### Maintenance

Rigid Sheet: For general cleaning, use Antibacterial fantastik® All Purpose Cleaner Heavy Duty. Use a clean, lint-free cloth and wipe clean.

For tough stains, like markers, pencil, white marks, and rubber heel marks, the following was shown to be most effective: Do not use any abrasive cleaning cloths or sponges.

- Zep® Heavy Duty Citrus Degreaser
- Clorox® Clean-up with Bleach
- Antibacterial fantastik® All Purpose Cleaner Heavy Duty
  1. Spray products onto sheet and wipe with a dampened cloth.
  2. Repeat process if stain remains. If cleaning product residue remains, rinse with water.

Note: Any reference to a specific branded product does not constitute an endorsement by Acculine.

### After Installation

Maintain environmentally controlled conditions after the installation. Large temperature changes can cause delamination.

- Maintain environmentally controlled conditions.
- Large temperature changes can cause de-lamination.

# Installation Instructions

## Palladium Rigid Vinyl Wall Sheet/Rub Strip

---

### Important Notes

1. Store all materials in an indoor location that is clean, dry and away from direct sunlight. Temperature is to be between 10°C and 35°C.
2. Maintain a climate-controlled installation area.
3. When installing, choose and maintain a temperature between 65°F-80°F and a humidity level below 80%, 24 hours before and during installation
4. Maintain temperatures between 18°C and 27°C after installation.
5. Do not install sheet if the moisture content of the drywall is greater than 4%.
6. Acclimate sheet, trim and adhesives to the installation temperature 24 hours before installation.
7. With large orders of sheet, acclimate the sheet in stacks of 25.
8. Unroll rolled sheet material immediately upon receipt and allow it to lay flat. Failure to do this may result in the sheet pulling away from the wall.
9. Do not expose sheet material to ultraviolet light. Exposure to UV may result in fading or colour change.
10. Do not install sheet material in direct sunlight or areas of elevated temperature. Excessive heat may cause bubbles and/or distorted sheet.
11. Cut sheet material with a metal straight edge and a sharp utility knife. Multiple cuts may be required.
12. Maximum installed sheet length is 3660mm.
13. Leave a 1/16" gap between sheets for expansion and contraction. Use Fastfill™ Colour Matched Caulk to fill the gap.
14. Leave 1.5mm gap between sheet material and doorjamb, baseboards and ceilings. Use Fastfill™ Colour Matched Caulk to fill the gap.
15. Leave oversized openings in the sheet for pipes, ducts, etc. to allow for expansion. Use Fastfill™ Colour Matched Caulk as needed.
16. Use pick resistant Fastfill™ Colour Matched Caulk. Do not use pick proof sealants. These do not allow for thermal movement.