

Installation Instructions

3D Trim – Partial Height with Colour Matched Caulk Joints

Please read all instructions before installing Palladium 3D Trim Wall System.

1. Before installation:
 - a. Acclimate IPC rigid sheet, Palladium 3D boards, adhesives, and wall substrates to room temperature 24 hours before installation.
 - b. Allow rigid sheet to lie flat 24 hours before installation.
 - c. 24 hours before, during and 48 hours after installation, maintain a building temperature between 20-26°C and keep humidity below 80%.
 - d. Substrate must be dry, well-sealed and free of dirt, loose paint, wax, and grease. Glossy surfaces may require sanding or priming to help promote adhesion.
 - e. Remove any coatings designed to improve clean-up as these coatings may affect adhesion.
 - f. InPro Bond or XT-2000+ adhesives can be used to apply rigid sheet to securely adhered vinyl wallcovering. Adhering rigid sheet over existing sheet or VWC will increase smoke generation, flame spread, and negate the Group 1 fire rating. If you choose to do this, follow the non-porous installation instructions that accompany InPro Bond and XT-2000+ adhesives.
 - g. Rolled Sheet – Unroll sheet immediately upon receipt of product. If roll set occurs, reverse roll sheet until sheet lays flat. With rolled sheet, follow non-porous installation instructions (see step 3). This allows the adhesive to become tackier. Keep sheet length to a maximum of 12' (3660mm).

Tools

Chalk Line or Laser Level, Level, Straight Edge, Tape Measure, Drop Cloth, Painter's Tape, Utility knife, Power Mitre Box, Carbide tipped saw blade with 60-80 teeth, Pneumatic Brad Nailer, 38mm Brad Nails, 3mm v-notched trowel with 13mm spacing, InPro Bond Adhesive, PL Premium Adhesive, Colour Matched Fill Stick

Chart #1

Trim Width	Gap
2" (51mm) Board/Corner	1" (25mm)
2-1/2" (64mm) Board	1-1/2" (38mm)
3" (76mm) Board/Corner	2" (51mm)
4" (102mm) Board/Corner	3" (76mm)
6" (152mm) Board/Corner	5" (127mm)
8" (203mm) Board/Corner	7" (178mm)
Trim Cap/ Trim Shoes	1" (25mm)

Installation Instructions

3D Trim – Partial Height with Colour Matched Caulk Joints

INPRO BOND ADHESIVE OR XT-2000+ ADHESIVE

1. Mark the wall with the locations of the gaps needed for Horizontal Boards, Vertical Boards and Corners. Follow the gap chart for the size of the horizontal boards, vertical boards and corners. Horizontal boards, vertical boards and corners overlap sheet 12mm. Apply painter's tape to the gaps.
2. Apply adhesive to the wall with a 3mm v-notched trowel with 12mm spaces between the notches. Allow the adhesive to tack up for 30-45 minutes. One section at a time, remove the tape from the wall. Position rigid sheet on wall. Repositioning of the rigid sheet on the wall can be done for 20-30 minutes. After rigid sheet is on the wall, apply heavy body pressure to the sheet with an IPC extension roller. Roll entire surface of the sheet.
3. Continue applying sheet to each section following the same steps. SEE FIG. 1

NOTE: Non-porous substrates that entrap water require longer drying times. When adhering rigid sheet to metal, plastic laminate, glazed block, rigid plastic or vinyl wallpaper, allow adhesive to dry a minimum of 1 hour but not more than 3 hours. Adhesive should be firm to the touch and not transfer off the substrate before applying the rigid sheet. When installing, keep material flat and properly aligned as you would with contact cement.

Remove excess adhesive with damp cloth before adhesive cures.

FIG. 1

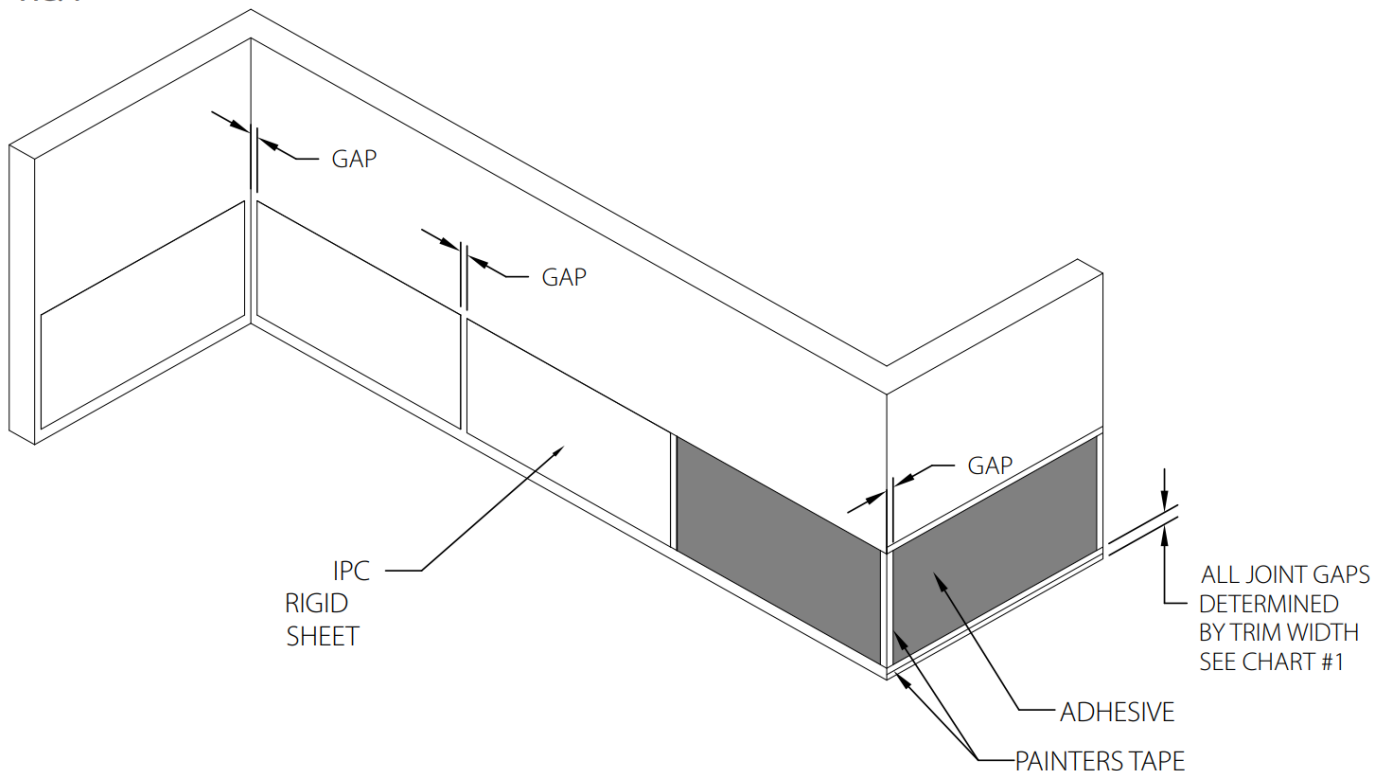

Installation Instructions

3D Trim – Partial Height with Colour Matched Caulk Joints

Installation of Horizontal Board or Trim Cap or Trim Shoe as Wall Base. SEE FIG. 2

1. Mitre cut the base inside corners, outside corner and lap joints. Apply a 5mm bead of PL Premium adhesive on the wall below the bottom edge of the sheet.
2. Install the wall base starting at an inside or outside corner. Position the wall base on the wall, pressing it to the wall to make firm contact with the adhesive. Nail with a pneumatic brad nailer 24" (610mm) O.C on wall base to help hold it in position until the adhesive sets-up. Do not nail through IPC Rigid Sheet.
3. Fill nail holes with colour matched filler.

See FIG. 5 for Palladium trim options.

Installation of Horizontal Top Cap, Trim Cap, Trim Shoe or Horizontal Decorative Moulding Board as the top board. SEE FIG. 2

1. Determine a level line at the top edge of the sheet for the top board.
2. Cut the horizontal top piece to length mitre cutting the inside corners, outside corners and lap joints.
3. Apply a 5mm bead of PL Premium above the top edge of the sheet making sure the adhesive will not go above the top of the top board.
4. Install the horizontal piece on the wall, pressing it to the wall to make firm contact with the adhesive.
5. Nail with a pneumatic brad nailer 24" (610mm) O.C on horizontal piece to help hold it in position until the adhesive sets-up. Do not nail through IPC Rigid Sheet.
6. Fill nail holes with colour matched filler.

See FIG. 5 for Palladium trim options

FIG. 2

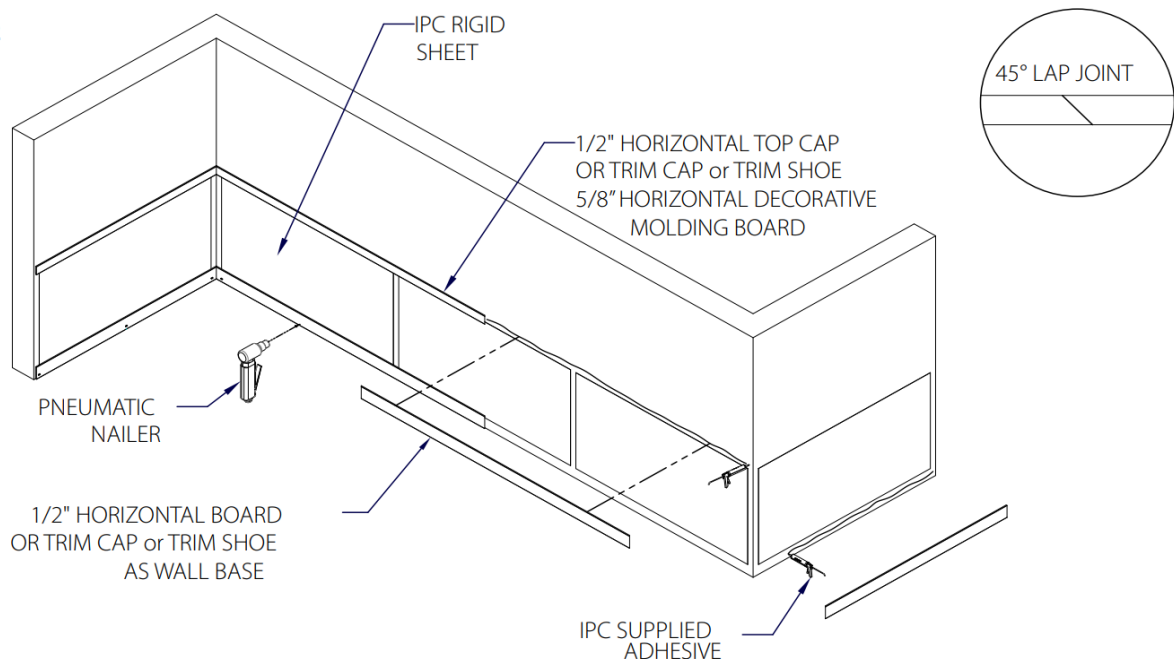

Installation Instructions

3D Trim – Partial Height with Colour Matched Caulk Joints

Installation of Vertical Boards, Vertical Decorative Moulding Board, Inside Corners and Outside Corners. SEE FIG. 31.

1. Cut the vertical boards, inside corners and outside corners to the distance between the wall base and the top board.
2. Apply a 5mm bead of PL Premium between the vertical edges of the sheet.
3. Install the vertical board on the wall, pressing it to the wall to make firm contact with the adhesive.
4. Nail with a pneumatic brad nailer 24" (610mm) O.C on vertical board to help hold it in position until the adhesive sets-up. Do not nail through IPC Rigid Sheet.
5. Fill nail holes with colour matched filler.

See FIG. 5 for Palladium trim options.

FIG. 3

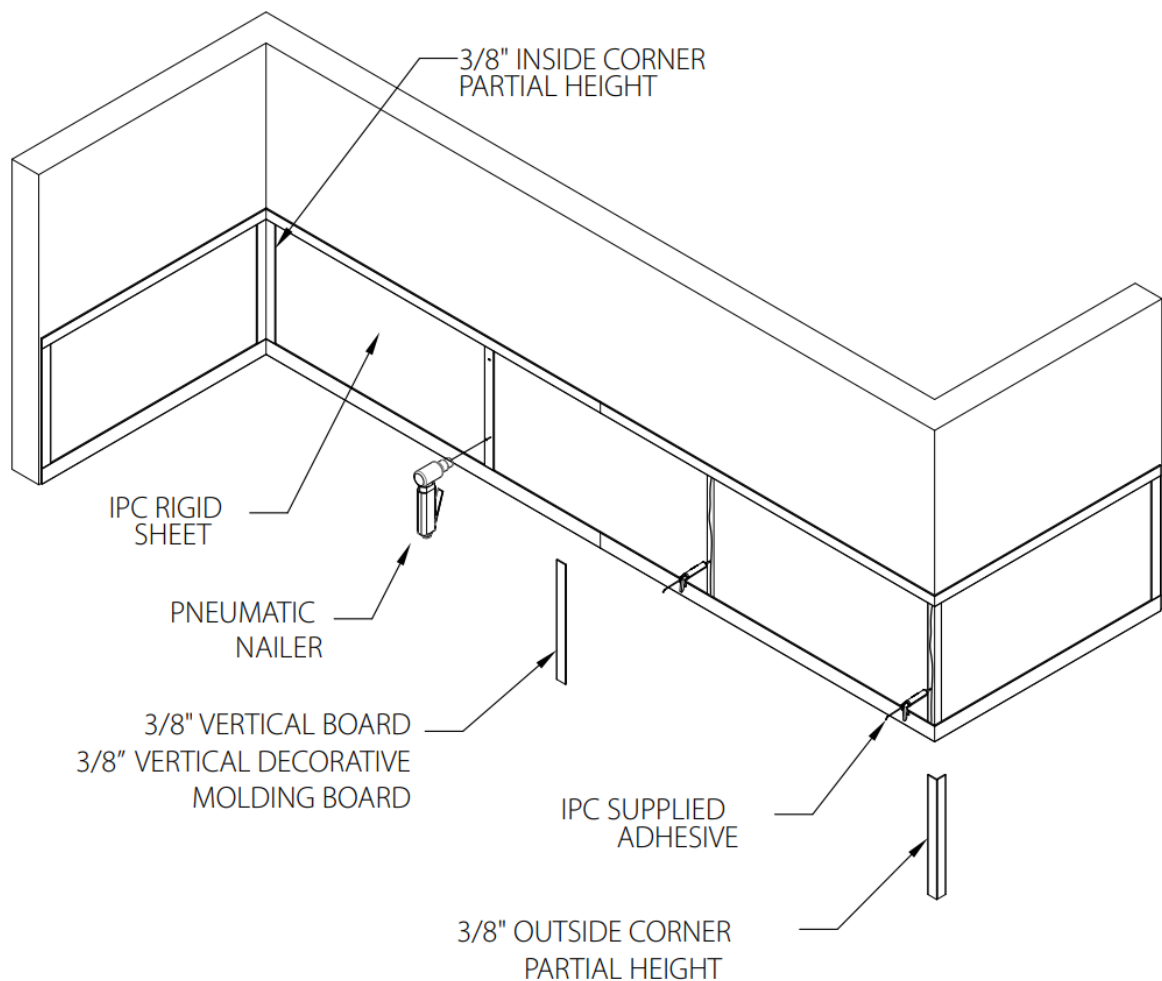

Installation Instructions

3D Trim – Partial Height with Colour Matched Caulk Joints

Installation of Horizontal Board SEE FIG. 4

1. Cut the Horizontal Board to length mitre cutting the inside corners, outside corners and lap joints.
2. Apply a 5mm bead of PL Premium between the edges of the sheet.
3. Install the Horizontal Board on the wall, pressing it to the wall to make firm contact with the adhesive.
4. Nail with a pneumatic brad nailer 24" (610mm) O.C on Horizontal Board to help hold it in position until the adhesive sets-up. Do not nail through IPC Rigid Sheet.
5. Fill nail holes with colour matched filler