

Installation Instructions

Joint System: 104-A07/A09

Note: Verify that the structural gap is in conformance with submittal data before beginning installation. If this is a Fire Rated Assembly, the fire barrier must be installed before the Architectural Joint System. Refer to the fire barrier instructions for specific system installation.

Fig. 1 (104-A07 Wall to Wall shown)

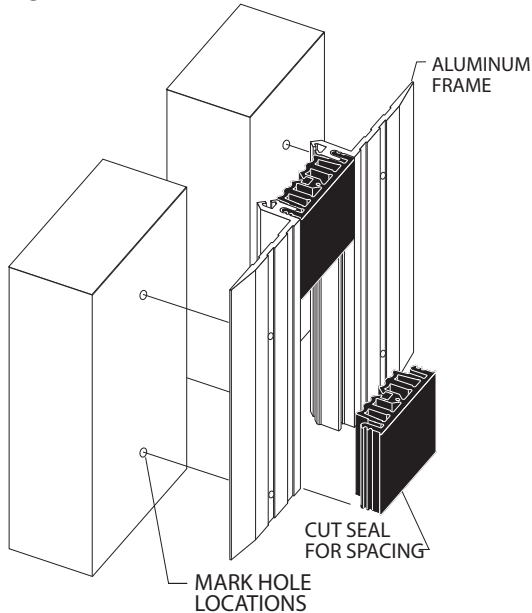
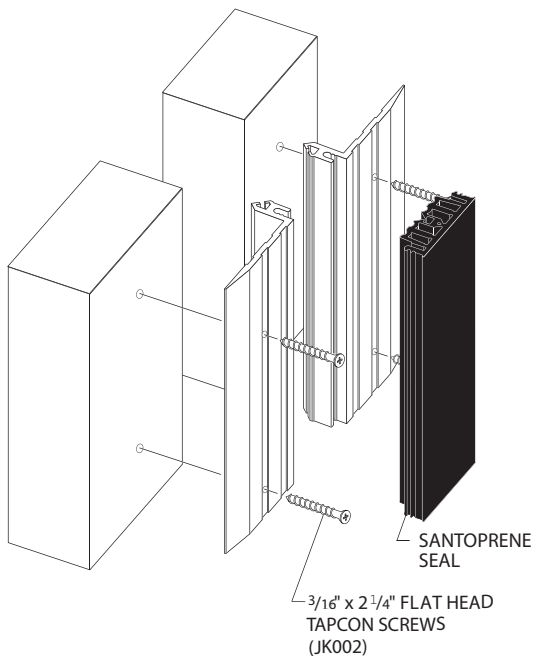

Fig. 2



1. Install the architectural joint system on a level wall surface. Shims may be required to raise the tops of the frames.

Figure 1

2. Cut the aluminum frames to the desired length.
3. To properly space frames, cut three small 2" [50mm] sections of seal. Insert one at each end and one in the center of each set of frames.
4. Center the frame assembly over the structural gap. Align plumb.
5. Mark the pre-drilled hole locations on the substrate.
6. Remove the frame assembly from the gap.

Figure 2

7. Drill holes on the substrate using a 1/8" (3mm) concrete drill bit to 2 3/8" (60mm) depth.
 - 7a. Optional Integral Vapor Barrier: Starting at one end of the frame assembly, slide vapor barrier into dart receptacles (see Figure 1a).
8. Return the frame assembly into position over the drilled hole locations. Secure the frames in place and remove the temporary spacers.
9. Press the Santoprene seal into the recessed slots of the frames until the seal is flush with the tops of the frames.

Fig. 1a.

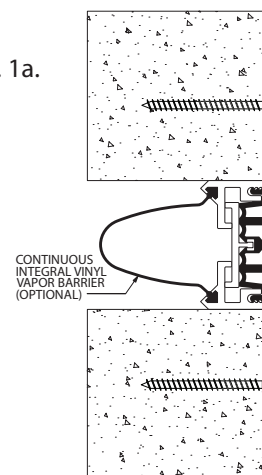

IPC.813/REV.2

JOINTMASTER® Expansion Joint Systems

inpro.com • 800.222.5556 • 262.679.9010

World Headquarters S80 W18766 Apollo Drive, Muskego, WI 53150 USA

Installation Hotline: 866.394.6776

inpro®

Installation Instructions

Joint System: 104-A07/A09

Fig. 3
(104-A07 Wall to Wall completed installation)

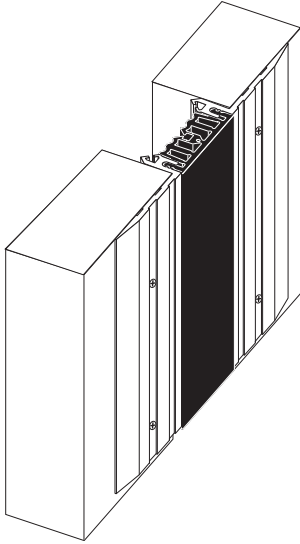

NOTE: To assist in installing the seal, apply a mist of soapy water solution to the back of the seal. A 1" [25mm] wide seam roller may be used to fully engage the seal ears into the frame slots.

Figure 3

10. Clean the exposed surfaces with a non-solvent cleaner, such as 409, as required.

(104-A09 Wall to Corner completed installation)

