

# Installation Instructions

Joint System: 426/428-A02

NOTE: Verify that the structural gap are in conformance with the submittal data before beginning installation. If this is a Fire Rated Assembly, the fire barrier must be installed before the Architectural Joint System. Refer to the fire barrier instructions for specific system installation.

FIG. 1

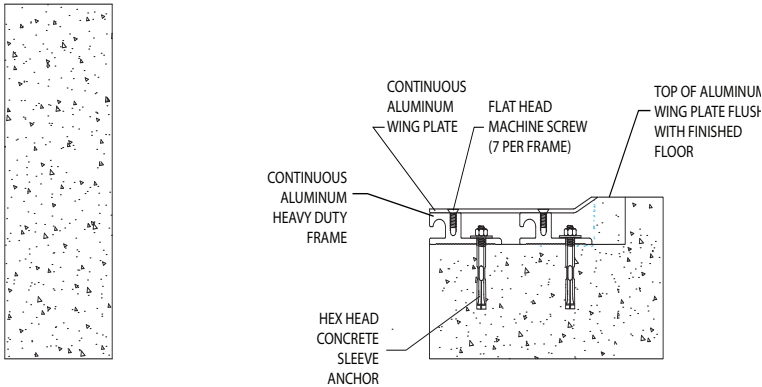

Figure 1

1. Install the architectural joint system on a level surface within the breakout. Make sure the tops of the recess plate are level with the finished floor height. This may require adding leveling compound to raise the tops of the frames.

FIG. 2

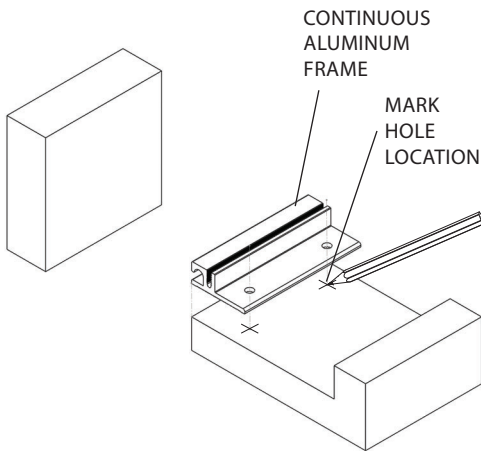

Figure 2

2. Cut the aluminum components to the desired length.
3. Align first aluminum frame to the edge structural gap.
4. Mark the pre-drilled hole locations on the floor substrate and remove from the breakout.

FIG. 3

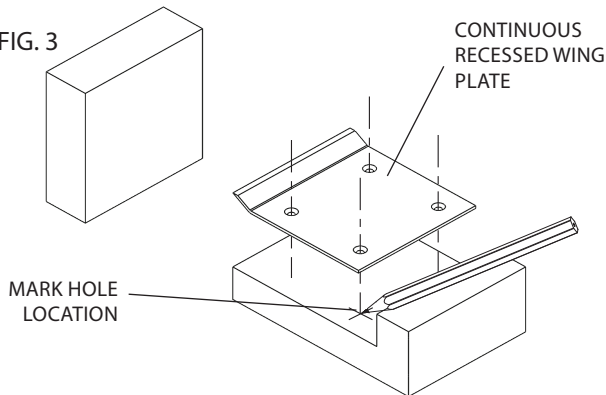

Figure 3

6. Place wing plate with back row of holes centered over the drilled hole locations for the front frame. Use the front row of holes on wing plate to mark the hole locations for the rear frame. Remove wing plate from breakout.
7. Drill holes into the breakout at marked hole locations using a 5/16" (8mm) concrete drill bit to 2 1/2" (63mm) depth.

IPC. 1347/Rev.3

Installation Hotline • 866.EZINPRO  
Inprocorp.com • 800.222.5556 • 262.679.9010  
World Headquarters S80 W18766 Apollo Drive, Muskego, WI 53150 USA

**JOINTMASTER®**  
EXPANSION JOINT SYSTEMS  
A DIVISION OF INPRO®

# Installation Instructions

Joint System: 426/428-A02

FIG. 4

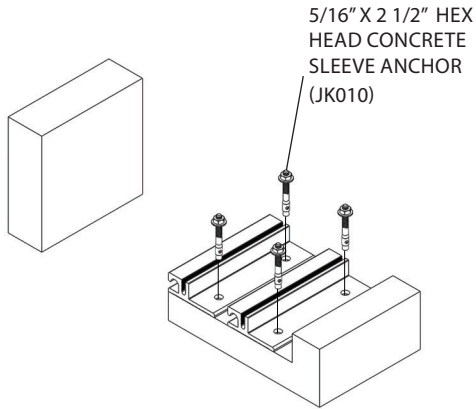

Figure 4

8. Return the frames into position over the drilled hole locations and secure using JK010 5/16" x 2 1/2" hex head concrete sleeve anchors.

FIG. 5

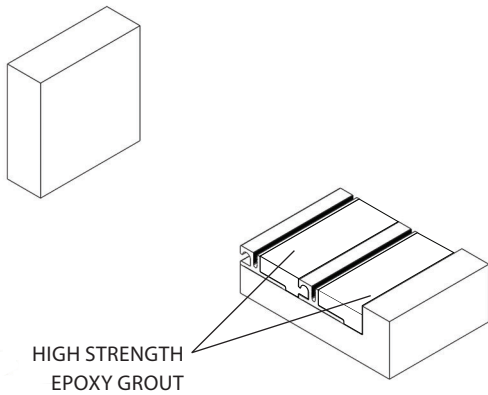

Figure 5

9. Blockout must be back filled in two stages. At the first stage fill with high strength epoxy grout level to top of frame. DO NOT go above frame.

FIG. 6

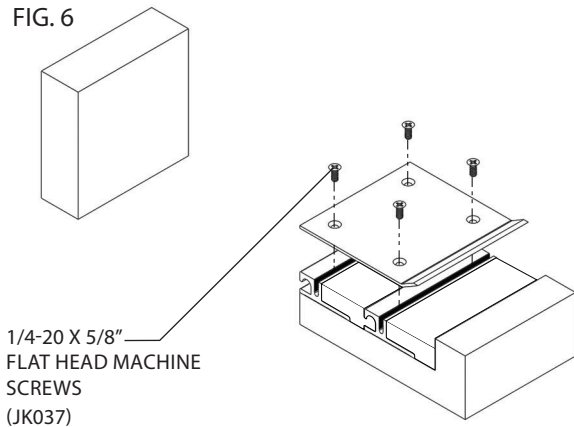

Figure 6

10. Place the cover over the frame so the pre-drilled holes in the cover align with the threaded slot in the frame below. Secure using JK037 1/4-20 x 5/8" flat head machine screws.

Installation Hotline • 866.EZINPRO

Inprocorp.com • 800.222.5556 • 262.679.9010

World Headquarters S80 W18766 Apollo Drive, Muskego, WI 53150 USA

**JOINTMASTER®**

EXPANSION JOINT SYSTEMS  
A DIVISION OF INPRO®

# Installation Instructions

Joint System: 426/428-A02

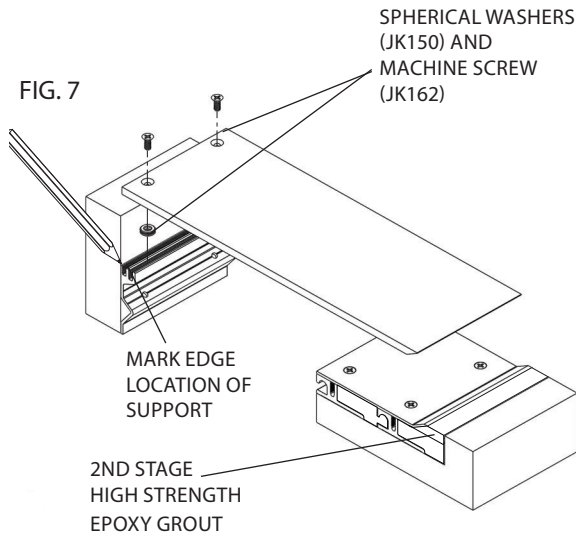

Figure 7

11. Complete second stage of backfilling with high strength epoxy grout material. Keep level to floor finish.

12. Attach the wall support to the cover plate using JK162 1/4" x 1" flat head machine screws and JK150 spherical washers (use JK194 flat head machine screw if using 1/4" cover plate). Place the half plate over the structural gap with the flat edge firmly against the finished wall. The horizontal base leg of the plate should rest firmly on the cover of the floor frame.

13. Mark the top edge of the wall support on the wall and remove cover plate. Then with the wall support lined up with the mark made for the top, mark the screw holes for drilling.

14. Drill holes on the wall using a 3/16" (4.5mm) concrete drill bit to 2 1/2" (64 mm) depth (make sure the angle matches that of the wall support holes).

Figure 8

15. Return the wall support into position over the drilled holes and secure using JK001 1/4" x 2 1/2" hex head concrete screw. Then secure the cover plate with JK162 machine screws and JK150 spherical washers. The half plate should rest level on the cover of the floor frame.

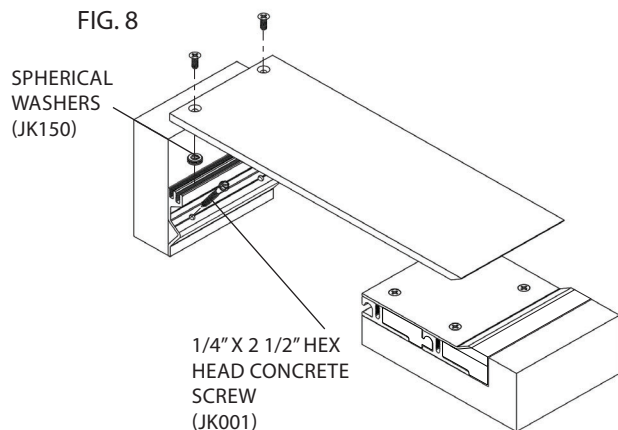
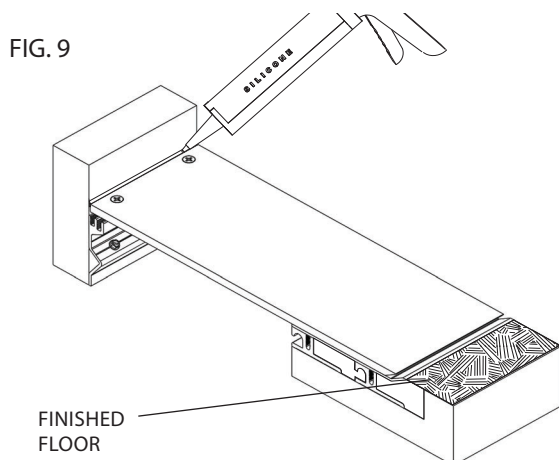

Figure 9

16. Apply silicone sealant in gap behind the continuous aluminum plate.

17. Install floor finish adjacent to the frame. Clean the exposed surfaces with a non-solvent cleaner, such as 409, as required.



Installation Hotline • 866.EZINPRO

Inprocorp.com • 800.222.5556 • 262.679.9010

World Headquarters S80 W18766 Apollo Drive, Muskego, WI 53150 USA

**JOINTMASTER®**  
EXPANSION JOINT SYSTEMS  
A DIVISION OF INPRO®