

Palladium® Full Wrap Square Profile Wall Panel,

Demountable, Factory Finished Edges

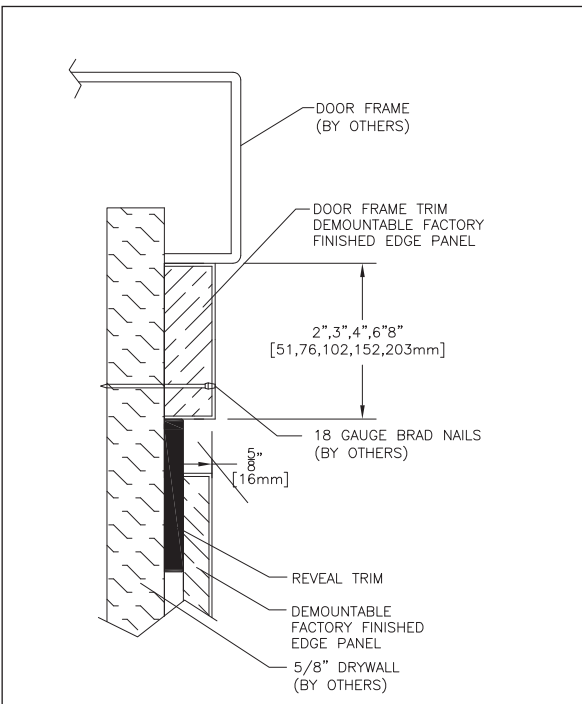
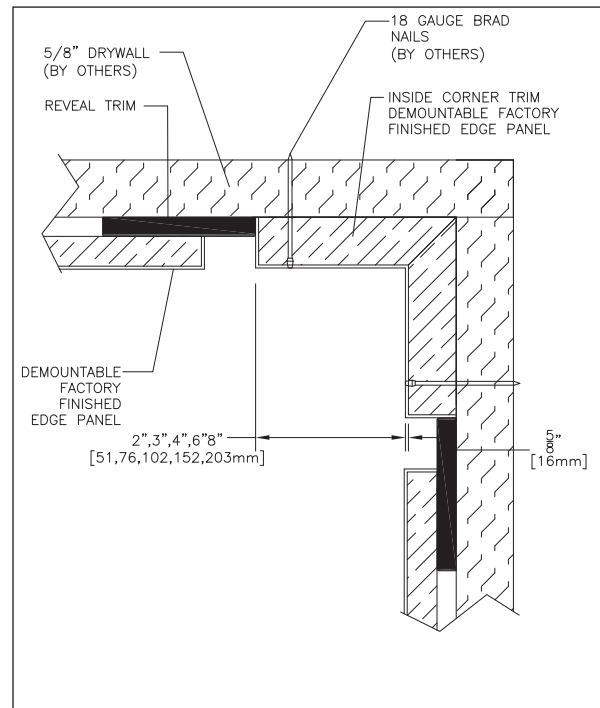
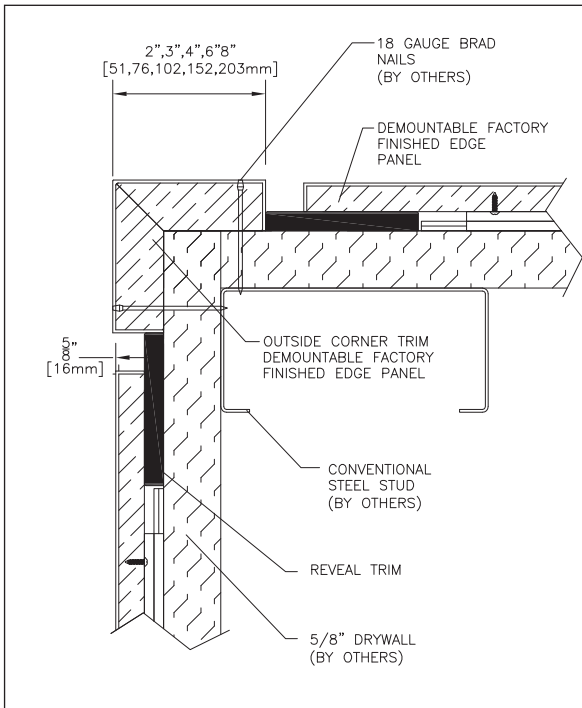

- Full Wrap Square Profile Panel System
- Demountable with "Z-clip" installation
- "EPT" - Edge Protection Technology resists edge damage
- Outside corner, inside corner and door frame trim available
- Reveal trim available
- Available in solid colors and patterns
- Meets the most rigorous standards and criteria of chemical emissions as prescribed by the GREENGUARD Environmental Institute
- Has been tested and meets GREENGUARD Environmental Institute's and the state of California's requirements for low emitting products as tested by Air Quality Sciences
- Has been tested and meets the GREENGUARD Children & School chemical emissions levels

IPC.2345/REV.2

Palladium® Full Wrap Square Profile Wall Panel, Demountable

Suggested Specification

PART 1 - GENERAL

1.01 SUMMARY

A. Palladium® Wall Panel system for wall protection and decoration

1.02 SECTION INCLUDES

A. Palladium® Full Wrap Square Profile Wall Panel System, Demountable Panels, Factory Finished Edges

1.03 REFERENCES

- A. American Society for Testing and Materials (ASTM)
- B. National Fire Protection Association (NFPA)
- C. Society of Automotive Engineers (SAE)

1.04 SYSTEM DESCRIPTION

A. Performance Requirements: Provide Palladium® Full Wrap Square Profile Wall Panel Systems that conform to the following requirements of regulatory agencies and the quality control of IPC Door and Wall Protection Systems, InPro Corporation.

1. Fire Performance Characteristics: Provide Palladium® Panels with materials conforming to NFPA Class A fire rating, with surface burning characteristics as determined by ASTM E-84. Outer rigid sheet shall have flame spread of 25 or less and smoke developed of 450 or less. MDF core shall have flame spread of 25 or less and smoke developed of 450 or less.
2. Chemical and Stain Resistance: Provide rigid vinyl that show resistance to stain when tested in accordance with applicable provisions of ASTM D-543.
3. Fungal and Bacterial Resistance: Provide rigid vinyl that does not support fungal or bacterial growth as tested in accordance with ASTM G-21 and ASTM G-22.
4. Color Consistency: Provide components matched in accordance with SAE J-1545 - (Delta E) with a color difference no greater than 1.0 units using CIE Lab, CIE CMC, CIE LCh, Hunter Lab or similar color space scale systems.
5. GREENGUARD Certified: Provide GREENGUARD Certified material. Panels, trim pieces and reveals shall meet the requirements of GREENGUARD Certification Standards for Low-Emitting Products and GREENGUARD Product Emission Standard for Children & Schools.
6. System Impact Resistance: Provide a panel system that resists impact as tested in accordance with applicable provisions of ASTM F 476-84, paragraph 18.

1.05 SUBMITTALS

- A. Product Data: Manufacturer's printed product data for each type of Palladium® Wall Panel System specified.
 - B. Detail Drawings: Mounting details with the appropriate adhesives for specific project substrates.
 - C. Samples: Verification samples of Palladium® Wall Panel, 6" (152mm) square, of each type and color indicated.
 - D. Manufacturer's Installation Instruction: Printed installation instructions for Palladium® Wall Panel Systems.
- 1.06 DELIVERY, STORAGE AND HANDLING
- A. Deliver materials in unopened factory packaging to the jobsite
 - B. Inspect materials at delivery to assure that specified products have been received.
 - C. Store in original packaging in a climate controlled location away from direct sunlight.
- 1.07 PROJECT CONDITIONS

A. Environmental Requirements: Products must be installed in an interior climate controlled environment.

1.08 WARRANTY

A. Standard IPC Limited Lifetime Warranty against material and manufacturing defects.

PART 2 - PRODUCTS

2.01 MANUFACTURER

A. Acceptable Manufacturer: IPC Door and Wall Protection Systems, InPro Corporation, PO Box 406 Muskego, WI 53150 USA;
Telephone: 800.222.5556, Fax: 888.715.8407, www.inprocorp.com

B. Substitutions: Not permitted

C. Provide all Palladium® Wall Panel Systems and wall protection from a single source.

2.02 MANUFACTURED UNITS

A. Wall Panel Systems

1. Palladium® Full Wrap Square Profile Wall Panel System, Demountable Panels, Factory Finished Edges

- a. Provide Palladium® Full Wrap Square Profile Wall Panel System with .375" (9.5mm) thick panels. Panel shall be constructed of rigid vinyl sheet permanently bonded to front surface and edges of MDF. Edges shall be bonded with "EPT" Edge Protection Technology. Back of panel shall be black.

Minimum Size – 6" (152mm) x 6" (152mm)

Maximum Size – 43" (1.09m) x 118" (2.99m)

Thickness – .375" (9.5 mm)

B. Trim

1. Palladium® Full Wrap Square Profile Wall Panel System Trim Pieces - Demountable Panels, Factory Finished Edges

a. Inside Corner

Width: 2" (51 mm), 3" (76 mm), 4" (102 mm), 6" (152 mm) or 8" (203 mm)

Thickness: .625" (16 mm)

Height: 96" (2.44 m)

b. Outside Corner

Width: 2" (51 mm), 3" (76 mm), 4" (102 mm), 6" (152 mm) or 8" (203 mm)

Thickness: .625" (16 mm)

Height: 96" (2.44 m)

c. Door Frame Trim

Width: 2" (51 mm), 3" (76 mm), 4" (102 mm), 6" (152 mm) or 8" (203 mm)

Thickness: .625" (16 mm)

Height: 96" (2.44 m)

d. Corner Guard Trim - (to be used with 160 or 150 High

Impact Corner Guards)

Width: 1.625" (41 mm) or 2.53" (64 mm)

Thickness: .188" (5 mm)

Height: 96" (2.44 m)

e. Reveals

2. Palladium® Panel System Reveal Pieces

a. Item Number, Width, Height, Thickness

Width: 2" (51 mm)

Thickness: .188" (5 mm)

Height: 96" (2.44 m)

3. Corner Guard Trim Reveals

Width: 2" (51 mm), 3" (76 mm) or 4" (102 mm)

Thickness: .188" (5 mm)

Height: 96" (2.44 m)

4. Corner Guard Trim - No Reveal (for use with High Impact Corner Guards)

Width: 2" (51 mm) or 3" (76 mm)

Thickness: .188" (5 mm)

Height: 96" (2.44 m)

2.03 MATERIALS

- A. Palladium® Full Wrap Square Profile Wall Panel System: Panels shall be made from .040" IPC Rigid Sheet factory bonded to MDF. MDF shall have No Added Urea Formaldehyde (nauf).
- B. Palladium® Trim Pieces: Trim Pieces shall be made from .040" IPC Rigid Sheet factory bonded to MDF Board. MDF board shall have No Added Urea Formaldehyde (nauf).
- C. Palladium® Corner Guard Trim: Corner guard trim shall be made from .040" IPC Rigid Sheet factory bonded to MDF Board. MDF board shall have No Added Urea Formaldehyde (nauf).
- D. Vinyl: IPC Rigid Sheet shall be manufactured from chemical and stain resistant polyvinyl chloride with the addition of impact modifiers. No plasticizers shall be added (plasticizers may aid in bacterial growth).

2.04 FINISHES

- A. Color or pattern of Palladium® Wall Panels to be selected by the architect from the IPC finish selection. Surface shall have a velvet texture. Select patterns shall have a smooth texture. Back of panels shall be black.
- B. Color or pattern of Palladium® Panel Trim Pieces to be selected by the architect from the IPC finish selection. Surface shall have a velvet texture. Select patterns shall have a smooth texture. Back of trim pieces shall be black.
- C. Color or pattern of Palladium® Panel reveals to be selected by the architect from the IPC finish selection. Surface shall have a velvet texture. Select patterns shall have a smooth texture. Back of trim pieces shall be black.

2.05 ACCESSORIES

- A. PL Premium Adhesive
 1. #535, 10 ounce cartridge
 2. #536, 28 ounce cartridge
- B. Hot Melt Adhesive
- C. Clear Silicone Sealant
- D. Fasteners: All mounting system accessories appropriate for substrates indicated on the drawing shall be provided.
 1. 2" "Z-clips" with screws for back of panels
 2. Continuous "Z-clips" for wall mounting.

PART 3 - EXECUTION

3.01 EXAMINATION

- A. Examine areas and conditions in which the Palladium® Wall Panels will be installed.
 1. Complete all finishing operations, including painting, before beginning installation of panels.
- B. Wall surface shall be dry and free from dirt, grease and loose paint.

3.02 PREPARATION

- A. General: Prior to installation, clean substrate to remove dust, debris and loose particles.

3.03 INSTALLATION

- A. General: Locate the Palladium® Wall Panels as indicated on the approved detail drawing for the appropriate substrate and in compliance with the IPC installation instructions. Install level and plumb at the height indicated on the drawings.

3.04 CLEANING

- A. At completion of the installation, clean surfaces in accordance with the IPC clean-up and maintenance instructions.