

Palladium® Rigid Vinyl Door Edge Protector

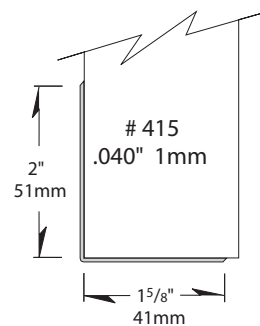
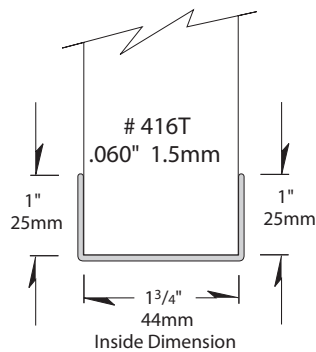

- **L-Shaped** available in 3' (.91m) standard height, custom heights available
- L-Shaped installation - adhesive mounted
- **U-Shaped** available in 3' (.91m) standard height, custom heights available
- U-Shaped installation available with pre-drilled, beveled holes or adhesive mount
- 3M Fastbond 30 Contact Cement or beveled head screws
- UL & cUL (Canada accepted) as cladding material

IPC.450/REV.9

Palladium® Rigid Vinyl Door Edge Protector

Suggested Specifications

PART 1 - GENERAL

1.01 SUMMARY

A. Door edge protectors for door protection

1.02 SECTION INCLUDES

A. Palladium® Rigid Vinyl Door Edge Protector

1.03 REFERENCES

- A. American Society for Testing and Materials (ASTM)
- B. National Building Code of Canada (NBC)
- C. National Fire Protection Association (NFPA)
- D. Society of Automotive Engineers (SAE)
- E. Underwriters Laboratory (UL)
- F. Underwriters Laboratory of Canada (ULC)
- G. Underwriters Laboratory, Canada Accepted (cUL)
- H. Uniform Building Code (UBC)

1.04 SYSTEM DESCRIPTION

A. Performance Requirements: Provide door edge protectors that conform to the following requirements of regulatory agencies and the quality control of IPC Door and Wall Protection Systems™, InPro Corporation.

1. Fire Performance Characteristics: Provide UL Classified door edge protectors conforming with NFPA Class A fire rating. Surface burning characteristics, as determined by UL-723 (ASTM E-84), shall be flame spread of 10 and smoke development of 350 - 450. Provide ULC (Canada) listed door edge protectors conforming to the requirements of the National Building Code of Canada 1990, Subsection 3.1.13. Surface burning characteristics, as determined by CAN/ULC-S102.2, shall be flame spread of 15 and smoke developed of 35.

2. Fire Performance Characteristics: Provide UL Classified door edge protectors of, rigid vinyl sheet conforming with the NFPA Class A fire rating. Surface burning characteristics, as determined by UL-723, for protector installed with 3M Fastbond 30, shall be flame spread of 10 and smoke development of 95-140 for .040" (1mm) thick material or flame spread of 15 and smoke development of 300 for .060" (1.5mm) thick material. For protector installed with Super Tek Products, XT-2000 adhesive, shall be flame spread of 20 and smoke development of 60-105 for .040" (1mm) thick material or flame spread of 20 and smoke development of 250 for .060" (1.5mm) thick material. Provide ULC (Canada) listed protector conforming to the requirements of the National building Code of Canada 2010, Subsection 3.1.13. Surface burning characteristics, as determined by CAN/ULC-S102.2, shall be flame spread of 15 and smoke developed of 30.

3. Fire Performance Characteristics: Provide UL Classified Cladding Material for fire door and fire door frames intended for application on listed door frames used with hollow metal and steel covered composite type fire doors rated up to 3 hours in accordance with UL 10B. Provide cUL (Canada accepted) Cladding Material intended for application on listed fire door frames used on hollow metal and steel composite type fire doors rated up to 3 hours in accordance with CAN4-S104-M80.

4. Fire Performance Characteristics: Provide UL Classified Cladding Material for doors and door frames intended for application on classified door frames used with wood composite and wood core type fire doors rated up to 1-1/2 hours in accordance with UL10B. Provide cUL (Canada accepted) Cladding Material intended for application on classified wood composite and wood core type fire doors rated up to 1-1/2 hours in accordance with CAN4-S104-M80.

5. Self Extinguishing: Provide door edge protectors with a CC1 classification, as tested in accordance with the procedures specified in ASTM D-635-74, Standard Test Method for Rate of Burning and/or Extent and Time of Burning of Self-Supporting

Plastics in a Horizontal Position, as referenced in UBC 52-4-1988.

6. Impact Strength: Provide rigid vinyl profile materials that have an Impact Strength of 30.2 ft-lbs/inch of thickness as tested in accordance with the procedures specified in ASTM D-256-90b, Impact Resistance of Plastics.

7. Impact Strength: Provide rigid vinyl sheet materials that have an Impact Strength of 30.4 ft-lbs/inch of thickness as tested in accordance with the procedures specified in ASTM D-256-90b, Impact Resistance of Plastics.

8. Chemical and Stain Resistance: Provide door edge protectors that show resistance to stain when tested in accordance with applicable provisions of ASTM D-543.

9. Fungal and Bacterial Resistance: Provide rigid vinyl that does not support fungal or bacterial growth as tested in accordance with ASTM G-21 and ASTM G-22.

10. Color Consistency: Provide components matched in accordance with SAE J-1545 - (Delta E) with a color difference no greater than 1.0 units using CIE Lab, CIE CMC, CIE LCh, Hunter Lab or similar color space scale systems.

1.05 SUBMITTALS

A. Product Data: Manufacturer's printed product data for each type of rigid vinyl door edge protector specified.

B. Detail Drawings: Mounting details with the appropriate adhesives for specific project substrates.

C. Samples: Verification samples of rigid vinyl door edge protectors, 8" (203mm) long, of each type and color indicated.

D. Manufacturer's Installation Instruction: Printed installation instructions for rigid vinyl door edge protector.

1.06 DELIVERY, STORAGE AND HANDLING

A. Deliver materials in unopened factory packaging to the jobsite.

B. Inspect materials at delivery to assure that specified products have been received.

C. Store in original packaging in a climate controlled location away from direct sunlight.

1.07 PROJECT CONDITIONS

A. Environmental Requirements: Products must be installed in an interior climate controlled environment.

1.08 WARRANTY

A. Standard IPC Limited Lifetime Warranty against material and manufacturing defects.

PART 2 - PRODUCTS

2.01 MANUFACTURER

A. Acceptable Manufacturer: IPC Door and Wall Protection Systems™, InPro Corporation, PO Box 406 Muskego, WI 53150 USA; Telephone: 800-222-5556, Fax: 888-715-8407, <http://www.inprocorp.com>

B. Substitutions: Not permitted

C. Provide all Palladium® rigid vinyl door edge protectors and wall protection from a single source.

2.02 MANUFACTURED UNITS

A. Palladium® Rigid Vinyl Door Edge Protectors

1. #415 L-Shaped, Size: 2" (51mm) X 36" (914mm), standard height, custom heights available, Thickness: .040" (1mm), Application: Factory Applied Adhesive Backing or Fastbond 30 Contact Cement

2. #416T U-Shaped, Size: 1" (25mm) X 1-3/4" (44mm) X 1" (25mm), 36" (914mm) standard height, custom heights available, Thickness: .060" (1.5mm), Application: Contact cement or countersunk flat head screws

2.03 MATERIALS

A. Vinyl: Palladium® Rigid Vinyl Door Edge Protectors shall be manufactured from chemical and stain resistant polyvinyl chloride with the addition of

impact modifiers. No plasticizers shall be added (plasticizers may aid in bacterial growth).

2.04 FINISHES

A. Colors of the Palladium® Rigid Vinyl Door Edge Protectors to be selected by the architect from the IPC finish selection. Surface shall have a velvet texture.

B. Patterns of the smooth door edge protectors to be selected by the architect from the IPC finish selection. Surface shall have a smooth finish.

PART 3 - EXECUTION

3.01 EXAMINATION

A. Examine areas and conditions in which the door edge protector systems will be installed.

1. Complete all finishing operations, including painting, before beginning installation of door edge protector system materials.

B. Door surface shall be dry and free from dirt, grease and loose paint.

3.02 PREPARATION

A. General: Prior to installation, clean substrate to remove dust and debris.

3.03 INSTALLATION

A. General: Locate door edge protector as indicated on the approved detail drawing for the appropriate substrate and in compliance with the IPC installation instructions. Install door edge protector at the height indicated on the drawings.

B. Installation of Palladium® Rigid Vinyl Door Edge Protector

1. Allow the door edge protector to reach room temperature before installing. The surface that the door edge protector is to be applied must be dry and free of dirt, oil, loose paint, wax and grease.

2. Check the door clearance to see if the door will close properly with the door edge protector in place. If needed plane the edge of the door, where the door edge will be mounted, until there is proper clearance.

3. U-Shaped installation: Fasteners - Position the door edge protector on the door and secure it with self tapping screws. Contact Cement - Apply contact cement to the door edge protector and the edge of the door. Allow the contact cement to completely dry. Position the door edge protector on the door, making firm contact between the two surfaces.

4. L-Shaped installation: Factory applied adhesive - Peel the release backing from the door edge protector and position it on the door. Press the protector to the door applying firm pressure to the entire surface. Contact Cement - Apply contact cement to the door edge protector and the edge of the door. Allow the contact cement to completely dry. Position the door edge protector on the door, making firm contact between the two surfaces.

3.04 CLEANING

A. At completion of the installation, clean surfaces in accordance with the IPC clean-up and maintenance instructions.