

Installation Instructions

Aluminum Corner Guards

Please read all instructions before installing corner guard.

Important

1. Acclimate materials 24 hrs before installation. Maintain temperature controlled environment after installation
2. Install in accordance with manufacturer's installation instructions. Failure to do so will void the warranty.

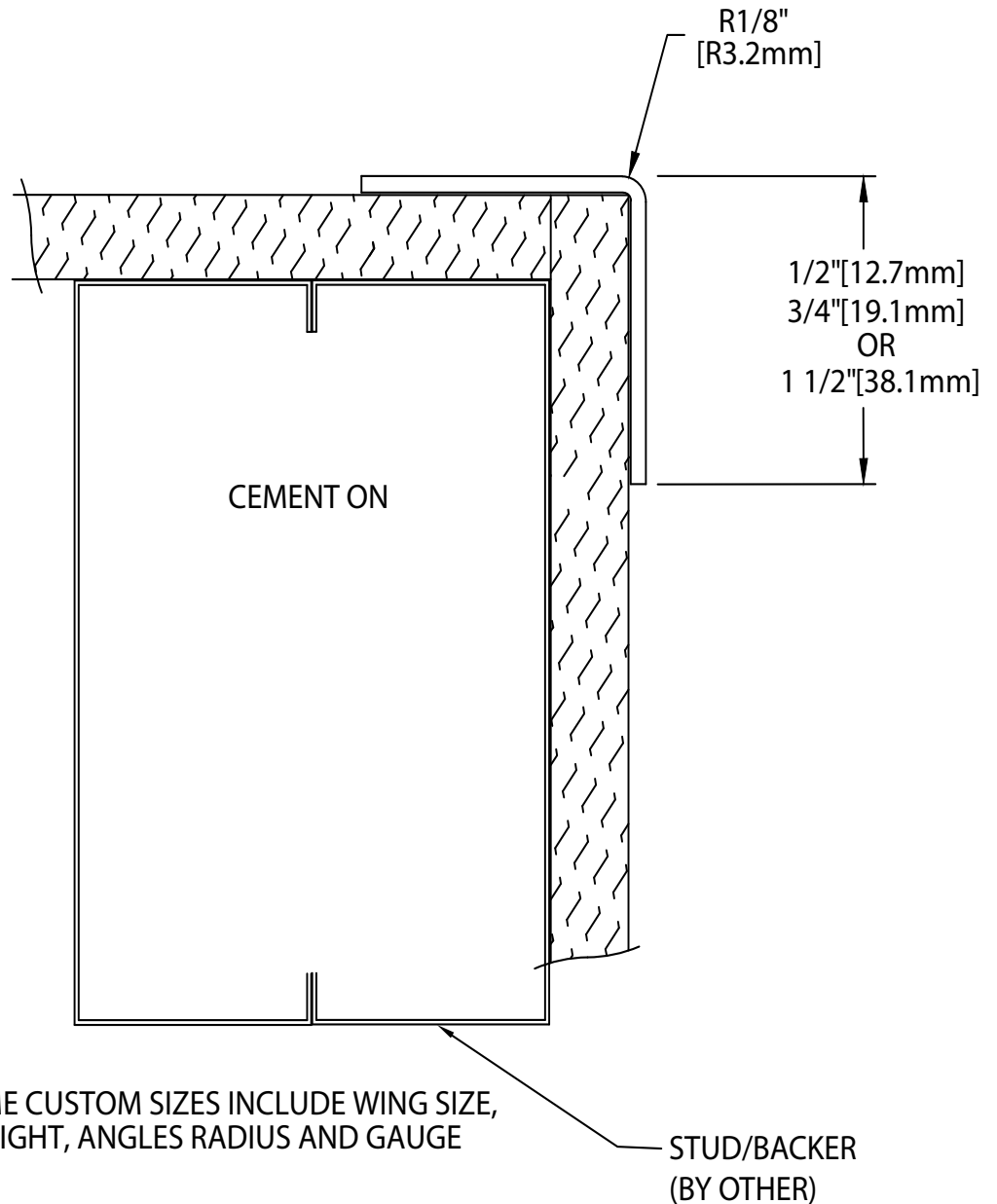

SECTION VIEWS

Recommended tools

Safety Glasses, Tape Measure, Level, Power Miter Saw, 10" Blade with 60-80 Carbide Tipped Teeth

IPC.1332/REV3

IPC® Door + Wall Protection

inpro.com • 800.222.5556 • 262.679.9010

World Headquarters S80 W18766 Apollo Drive, Muskego, WI 53150 USA

Installation Hotline: 866.394.6776

inpro®

Installation Instructions

Aluminum Corner Guards

Please read all instructions before installing corner guard.

Components and Fasteners

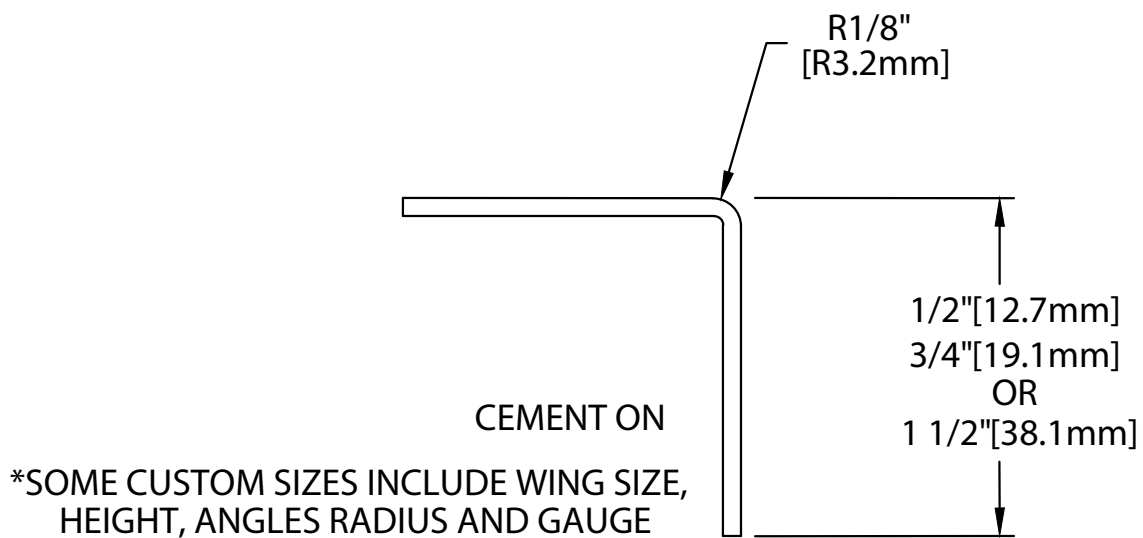

SHOWN AT 1 1/2"

IPC® Door + Wall Protection

inpro.com • 800.222.5556 • 262.679.9010

World Headquarters S80 W18766 Apollo Drive, Muskego, WI 53150 USA

Installation Hotline: 866.394.6776

inpro®

Installation Instructions

Aluminum Corner Guards

Please read all instructions before installing corner guard.

Exploded View assembly

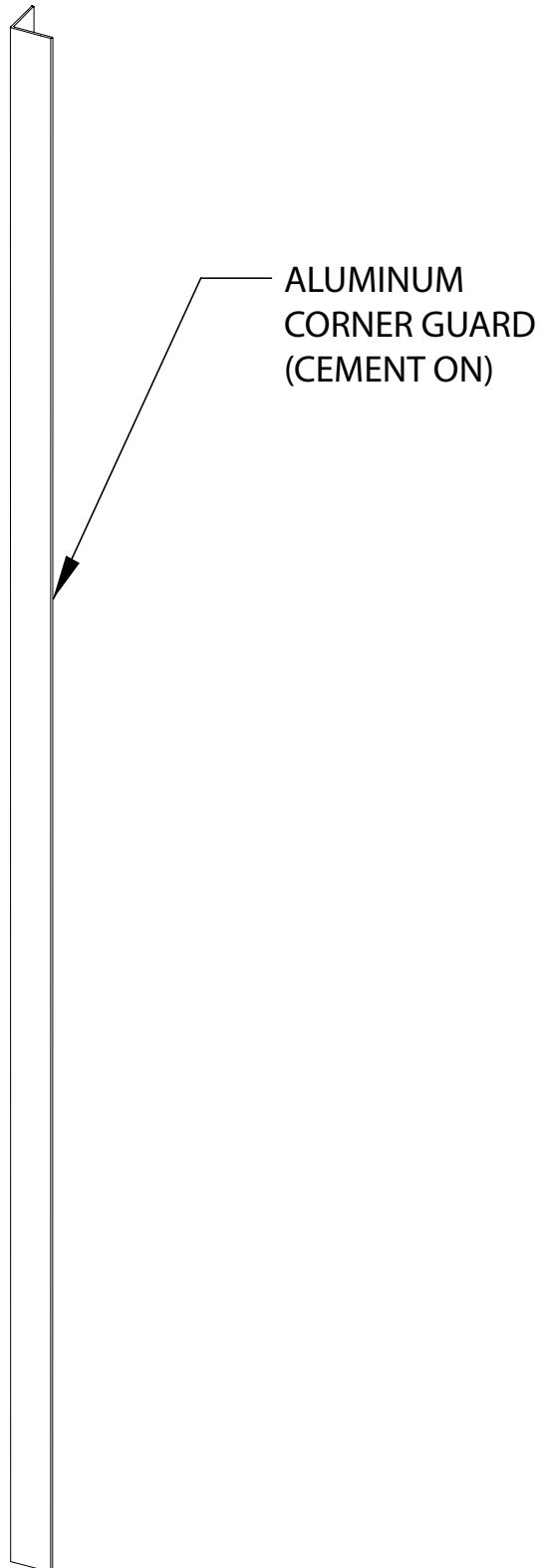

IPC® Door + Wall Protection

inpro.com • 800.222.5556 • 262.679.9010

World Headquarters S80 W18766 Apollo Drive, Muskego, WI 53150 USA

Installation Hotline: 866.394.6776

inpro®

Installation Instructions

Aluminum Corner Guards

Please read all instructions before installing corner guard.

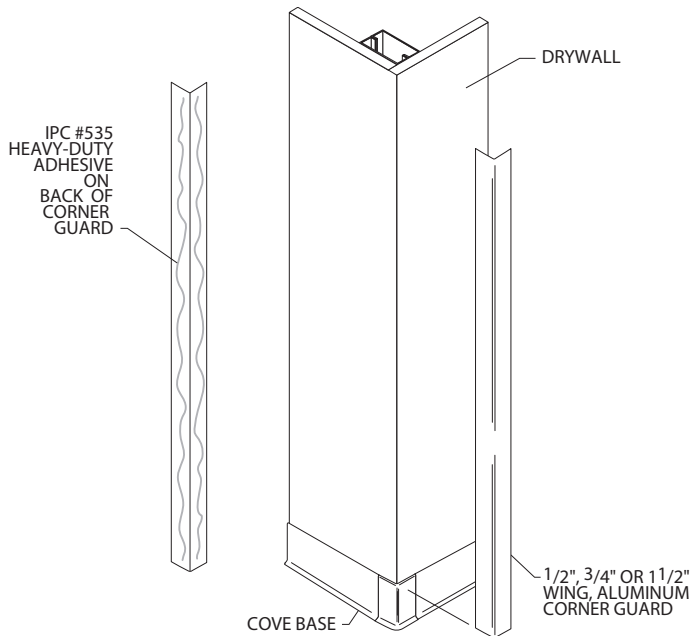

Please read all instructions before installing corner guards. Material must be stored, installed and used in environmentally controlled conditions.

1. Prior to installation:
 - a. Allow corner guards to reach room temperature before installing.
 - b. The wall surface that the corner guards are to be applied must be dry and free of dirt, dust, oil, loose pain, wax and grease.
2. Use IPC #535 Heavy-Duty Adhesive to adhere corner guards. Apply a bead of IPC #535 in a zig-zag pattern over the back of the corner guard.
3. Immediately position corner guard on the wall and apply pressure until a tight fit is achieved. An extension roller will aid this step. Additional bracing may be required during installation to insure complete contact with the wall.
4. Remove protective plastic film from exposed surface.

Adhesive Coverage: One 10.6 oz cartridge of IPC #535 Heavy-Duty Adhesive will adhere the following corner guards based on an approximate cover of 70 lf per cartridge.

Wing Size	Height	# of Corner Guards per cartridge
1/2", 3/4", 1-1/2"	12'	3

IPC® Door + Wall Protection

inpro.com • 800.222.5556 • 262.679.9010

World Headquarters S80 W18766 Apollo Drive, Muskego, WI 53150 USA

Installation Hotline: 866.394.6776

inpro®